

Platinum Bee **Digital Servo Drive Installation** **Guide**

Functional Safety
Safety Capability F, S, O
EtherCAT and CANopen

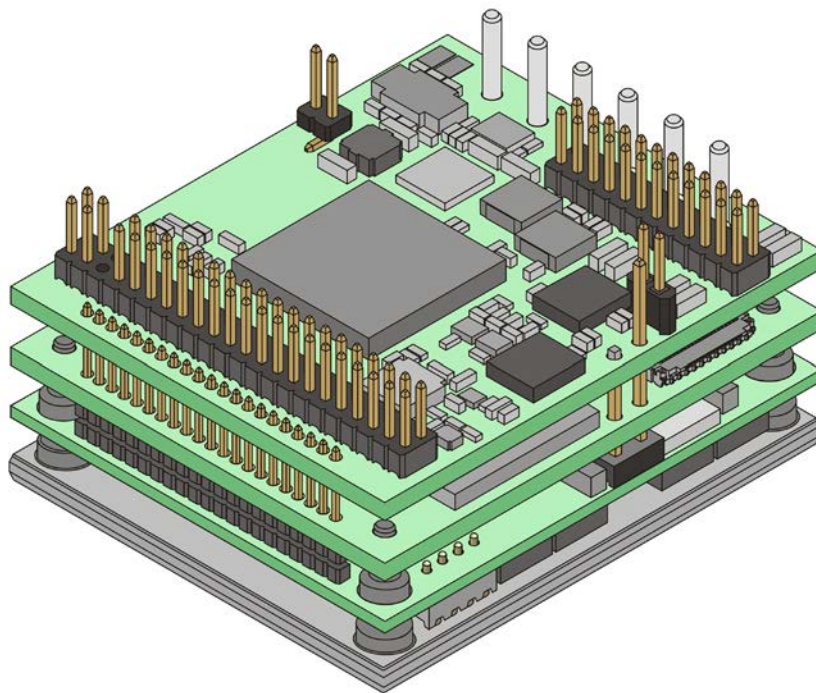

March 2025 (Ver. 3.004)

This guide is delivered subject to the following conditions and restrictions:

- This guide contains proprietary information belonging to Elmo Motion Control Ltd. Such information is supplied solely for the purpose of assisting users of Elmo's servo drive(s) in their installation.
- The text and graphics included in this manual are for the purpose of illustration and reference only. The specifications on which they are based are subject to change without notice.
- Elmo Motion Control and the Elmo Motion Control logo are trademarks of Elmo Motion Control Ltd.
- Information in this document is subject to change without notice.



Elmo Motion Control and the Elmo Motion Control logo are registered trademarks of Elmo Motion Control Ltd.



EtherCAT® and Safety over EtherCAT® are registered trademarks and patented technologies, licensed by Beckhoff Automation GmbH, Germany.



EtherCAT® Conformance tested is a registered trademark and patented technology, licensed by Beckhoff Automation GmbH, Germany.



CANopen compliant. CANopen® is a registered trademark and patented technology, licensed by CAN in Automation (CiA) GmbH, Kontumazgarten 3, DE-90429 Nuremberg, Germany.

Document no. MAN-P-BEEIG (Ver. 3.004)

Copyright © 2025

Elmo Motion Control Ltd.

All rights reserved.



Catalog Number

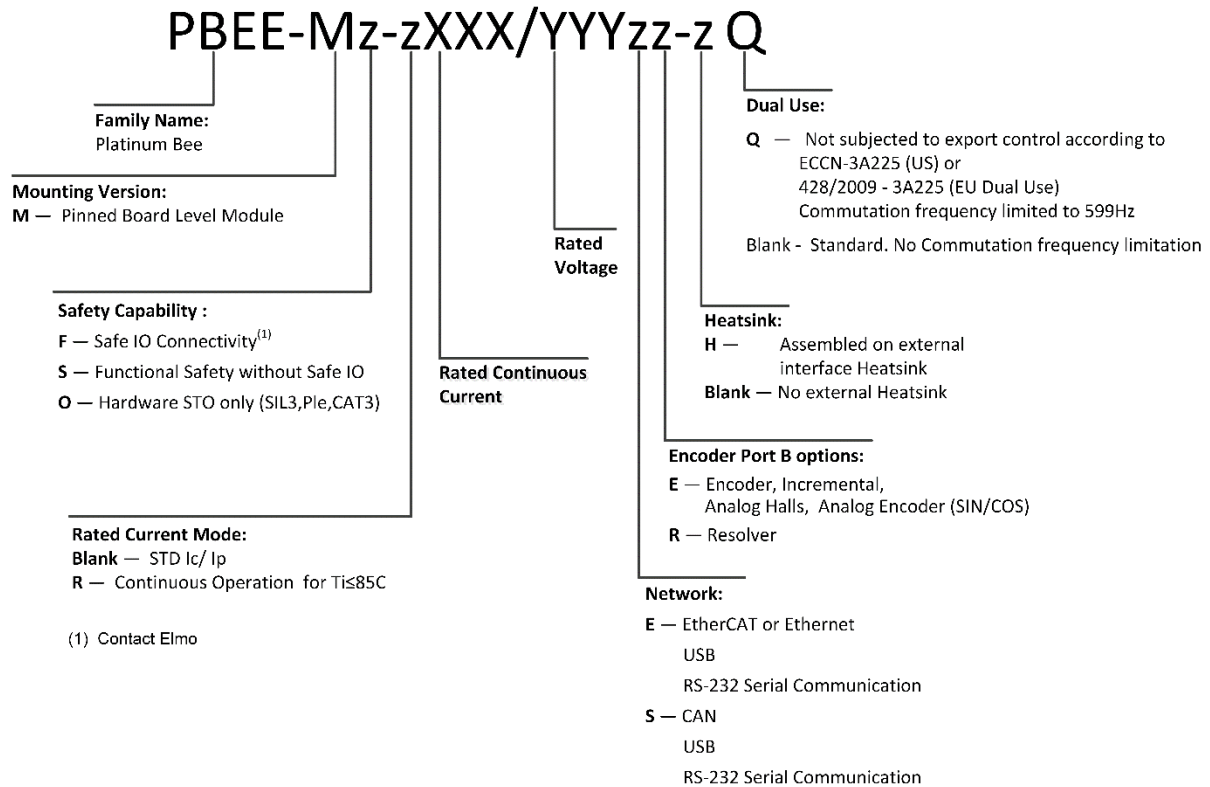

Revision History

Version	Date	Details	Version	Date	Details
Ver. 1.000	July 2020	Initial Release	Ver. 2.010	Oct 2021	Update to section 5.5 Product Features
Ver. 1.001	Aug 2020	Several updates	Ver. 2.011	Nov 2021	Update to Chap. 5 Technical Information
Ver. 2.000	Aug 2020	Several updates	Ver. 2.012	Jan 2022	Several updates
Ver. 2.001	Aug 2020	Several updates	Ver. 2.013	Mar 2022	Several updates
Ver. 2.002	Aug 2020	Several updates	Ver. 2.014	May 2022	Updates
Ver. 2.003	Aug 2020	Several updates	Ver. 2.015	Jun 2022	Updates
Ver. 2.004	Sept 2020	Several updates	Ver. 2.016	Jan 2023	Updates
Ver. 2.005	Nov 2020	Several updates	Ver. 3.000	May 2023	Safety Configuration update to include Safe IO Connectivity
Ver. 2.006	Feb 2021	Several updates	Ver. 3.001	Jun 2023	Heat Diss. Graph added to section 9.2.1
Ver. 2.007	Feb 2021	Several updates	Ver. 3.002	Sep 2023	Updated Chapter 5 Tech. Information
Ver. 2.008	Mar 2021	Several updates	Ver. 3.003	Sept 2024	Updated Part Number and drawings. CANopen available, updated CAN-info and added new sections 8.2.2 and 8.11.4.
Ver. 2.009	Aug 2021	Several updates	Ver. 3.004	Mar 2025	Updated section 8.9.1 and Fig. 25 Updated in section 8.9.1

Chapter 1:	This Installation Guide.....	7
Chapter 2:	Functional Safety.....	7
Chapter 3:	Safety Information	7
3.1	Warnings.....	8
3.2	Cautions.....	8
3.3	CE Marking Conformance.....	8
3.4	Warranty Information	8
Chapter 4:	Product Description.....	9
Chapter 5:	Technical Information	10
5.1	Physical Specifications.....	10
5.2	Current/Voltage Technical Data	10
5.2.1	100V Models	10
5.2.2	200V Models	11
5.2.3	R Type Models Operating at -40 to 62 °C (-40 to 143.6 °F)	11
5.2.4	R Type Models Operating at -40 to 71 °C (-40 to 159.8 °F)	12
5.3	Control Supply	13
5.4	Encoder Supply.....	13
5.5	Product Features	13
5.5.1	Analog Input.....	13
5.5.2	General Product Features	13
5.5.3	IO Features Module.....	13
5.6	Environmental Conditions	14
5.6.1	ExtrIQ Conditions	14
5.6.2	Functional Safety.....	15
5.7	Standards and Certifications.....	16
5.7.1	Functional Safety.....	16
5.7.2	Electrical Safety	16
5.7.3	Electromagnetic Compatibility.....	16
5.7.4	Environmental.....	17
5.7.5	Other Compliant Standards.....	17
5.7.6	Dual Use	17
Chapter 6:	Installation	18
6.1	Unpacking the Drive Components.....	18
6.2	Over-Current and Short-Circuit Protection.....	18
6.3	Mounting the Platinum Bee	19
6.3.1	Mounting Platinum Bee to an External Heatsink	20
Chapter 7:	Connections	21

7.1	Motor Power Pins.....	22
7.2	Main Power Pins.....	22
7.3	Control Supply Pins.....	23
7.4	Feedback Pins (FDB)	24
7.5	Main Pins (MAIN).....	25
7.6	Drive Status Indicator	27
7.7	Extended IO Pins.....	27
7.8	3.3V Pins	28
Chapter 8:	Wiring	29
8.1	Wiring Legend.....	29
8.2	The Platinum Bee Connection Diagrams	30
8.2.1	EtherCAT Connection Diagram.....	30
8.2.2	CAN Connection Diagram.....	31
8.3	Integrating the Platinum Bee on a PCB	32
8.3.1	Power Returns (PR)	32
8.3.2	Common Return (COMRET).....	32
8.3.3	Earth Connection (PE)	32
8.3.4	Power Return (PR), Common Return (COMRET) and Earth Connections (PE)	32
8.4	Logic and Control Cabling and Wiring.....	33
8.4.1	Feedback Ports, VL, RS232, RS422, Analog Input, USB	33
8.4.2	Digital Inputs/Outputs, STO	33
8.4.3	EtherCAT and CAN Communications.....	33
8.5	Power Conductors PCB layout	33
8.6	Motor Power (M1).....	34
8.6.1	Connections.....	34
8.7	Main Power and Control Connector.....	35
8.7.1	Main Power	35
8.7.2	Control Supply Connections	35
8.7.2.1	Dual Power Supply Topology	35
8.8	Feedback.....	37
8.8.1	Feedback Port A	37
8.8.1.1	Incremental Encoder	37
8.8.1.2	Absolute Serial Encoder	38
8.8.1.3	Hiperface	38
8.8.2	Feedback Port B	39
8.8.2.1	Incremental Encoder	39
8.8.2.2	Interpolated Analog (Sine/Cosine) Encoder	40
8.8.2.3	Resolver	40
8.8.3	Feedback Port C.....	41

8.8.3.1	Incremental Encoder	41
8.8.3.2	Absolute Serial Encoder	42
8.8.3.3	Emulated Encoder Output	43
8.8.4	Feedback - Hall Sensors.....	43
8.9	Digital IO	44
8.9.1	Digital Inputs	44
8.9.2	Digital Outputs	45
8.9.3	STO (Safe Torque Off).....	46
8.10	Analog Inputs.....	47
8.10.1	Analog Input 1	47
8.10.2	Analog Input 2	47
8.11	Communication	48
8.11.1	Serial Communication	48
8.11.1.1	Standard RS-232 Serial Communication	48
8.11.1.2	RS-422 (Differential RS-232) Serial Communication	49
8.11.2	USB 2.0	50
8.11.3	EtherCAT/Ethernet Communication	51
8.11.3.1	EtherCAT Status Indicator.....	51
8.11.3.2	EtherCAT Link Indicators.....	51
8.11.4	CAN.....	52
Chapter 9:	Powering Up.....	53
9.1	Initializing the System.....	53
9.2	Heat Dissipation.....	53
9.2.1	Thermal Dissipation Data	53
9.2.2	How to Use the Chart.....	55
Chapter 10:	Dimensions	57
10.1	Platinum Bee without Heatsink.....	57
10.2	Platinum Bee with Heatsink	57

Chapter 1: This Installation Guide

This installation Guide details the technical data, pinouts, and power connectivity of the Platinum Bee.

For a comprehensive specification and detailed description of the functions, refer to the [Platinum Safety Drive](#).

Chapter 2: Functional Safety

The Platinum Bee servo drives support Functional Safety. It is necessary to implement the instructions in the [Platinum Safety Drive Manual](#) regarding using STO, Feedbacks, IOs and Power supplies with Functional Safety.

Chapter 3: Safety Information

In order to achieve the optimum, safe operation of the Platinum Bee, it is imperative that you implement the safety procedures included in this installation guide. This information is provided to protect you and to keep your work area safe when operating the Platinum Bee and accompanying equipment.

Please read this chapter carefully before you begin the installation process.

Before you start, ensure that all system components are connected to earth ground. Electrical safety is provided through a low-resistance earth connection.

Only qualified personnel may install, adjust, maintain and repair the servo drive. A qualified person has the knowledge and authorization to perform tasks such as transporting, assembling, installing, commissioning and operating motors.

The Platinum Bee contains electrostatic-sensitive components that can be damaged if handled incorrectly. To prevent any electrostatic damage, avoid contact with highly insulating materials, such as plastic film and synthetic fabrics. Place the product on a conductive surface and ground yourself in order to discharge any possible static electricity build-up.

To avoid any potential hazards that may cause severe personal injury or damage to the product during operation, keep all covers and cabinet doors shut.

The following safety symbols are used in this and all Elmo Motion Control manuals:



Warning:

This information is needed to avoid a safety hazard, which might cause bodily injury or death as a result of incorrect operation.



Hot Surface Warning:

To alert against surfaces that may reach high temperatures. The heatsink and wires may reach high temperatures.



Caution:

This information is necessary to prevent bodily injury, damage to the product or to other equipment.



Important:

Identifies information that is critical for successful application and understanding of the product.

The following symbols are used in this document:



Note:

Information critical to the understanding and/or operating the feature.



Tip:

Information that helps understanding a feature, is good practice or a possible different way of action.

3.1 Warnings

- To avoid electric arcing and hazards to personnel and electrical contacts, never connect/disconnect the servo drive while the power source is on.
- Power cables can carry a high voltage, even when the motor is not in motion. Disconnect the Platinum Bee from all voltage sources before servicing.
- The high voltage products within the Platinum Line range contain grounding conduits for electric current protection. Any disruption to these conduits may cause the instrument to become hot (live) and dangerous.
- STO circuits are separated from power circuits by reinforced insulation and can be supplied by SELV power supply. Other Control and communication level circuits are separated from power circuits by functional insulation. These circuits shall have insulation to their surroundings and other control or communication circuits based on the Working Voltage and requirements of the end use application.



Capacitance Discharge

After shutting off the power and removing the power source from your equipment, wait at least 2 seconds before touching or disconnecting parts of the equipment that are normally loaded with electrical charges (such as capacitors or contacts). Measuring the electrical contact points with a meter, before touching the equipment, is recommended.

3.2 Cautions

- The maximum DC power supply connected to the instrument must comply with the parameters outlined in this guide.
- When connecting the Platinum Bee to an approved control supply, connect it through a line that is separated from hazardous live voltages using reinforced or double insulation in accordance with approved safety standards.
- Before switching on the Platinum Bee, verify that all safety precautions have been observed and that the installation procedures in this manual have been followed.
- Make sure that the Safe Torque Off is operational.

3.3 CE Marking Conformance

The Platinum Bee is intended for incorporation in a machine or end product. The actual end product must comply with all safety aspects of the relevant requirements of the European Safety of Machinery Directive 2006/42/EC as amended, and with those of the most recent versions of standards EN 60204-1 and EN ISO 12100 at the least, and in accordance with 2006/95/EC.

Concerning electrical equipment designed for use within certain voltage limits, the Platinum Bee meets the provisions outlined in 2006/95/EC. The party responsible for ensuring that the equipment meets the limits required by EMC regulations is the manufacturer of the end product.

3.4 Warranty Information

The products covered in this manual are warranted to be free of defects in material and workmanship and conform to the specifications stated either within this document or in the product catalog description. All Elmo drives are warranted for a period of 12 months from the date of shipment. No other warranties expressed or implied — and including a warranty of merchantability and fitness for a particular purpose — extend beyond this warranty.

Chapter 4: Product Description

The Platinum Bee is an advanced high power density servo drive, delivering up to **5.6 kW power** in a 16.4 cm³ (1.0 in³) compact package (35 x 30 x 15.6 mm or 1.38" x 1.18" x 0.6"). The Platinum Bee is designed to be mounted on a PCB by soldering its pins directly to the PCB.

This advanced, high power density, servo drive provides top performance, advanced networking and built-in safety, as well as a fully featured motion controller and local intelligence.

The Platinum Bee is provided in three configurations:

- **PBEE-MO-zXXX/YYYzz-z** - Platinum Bee with STO (**SIL3, Ple, CAT3**).
The servo drive configuration supports only STO.
- **PBEE-MS-zXXX/YYYzz-z** - Platinum Bee with Function Safety excluding Safe IO
This configuration permits operation of safety functions only via FSOE (Fail Safe Over EtherCAT).
- **PTWI-MF-zXXX/YYYzz-z** – Platinum Bee with Functional Safety and the capability to add Safe IO to the the Platinum Board Level Module Integration
For details, refer to the **Platinum BLM Integration Board for Functional Safety** application note.



Important:

The integration board of the EtherCAT interface must be also designed and approved according to the safety standards IEC61800-5-2.

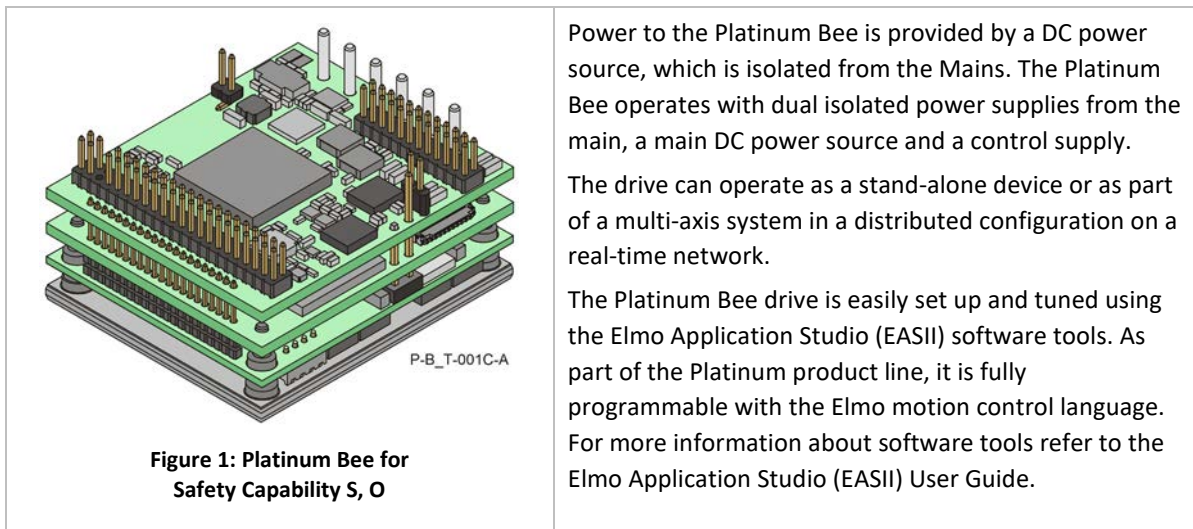

Figure 1: Platinum Bee for Safety Capability S, O

The Platinum Bee is available in a variety of models. There are a number of possible options, multiple power rating, various communications, and feedback.

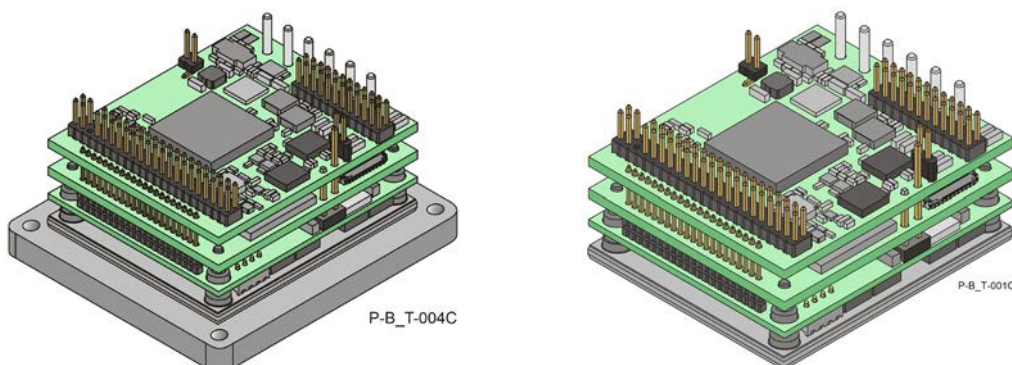

Figure 2: Platinum Bee modules with/without Heatsink

Chapter 5: Technical Information

5.1 Physical Specifications

Feature	Units	All Types
Weight without Heatsink	g (oz)	26.0 g (0.91 oz)
Weight with Heatsink	g (oz)	47.0 g (1.66 oz)
Dimension without Heatsink	mm (in)	35 x 30 x 15.3 mm (1.38" x 1.18" x 0.6")
Dimension with Heatsink	mm (in)	47 x 41.3 x 19.3 mm (1.85" x 1.63" x 0.76")
Mounting method		PCB mount
Degrees of Protection		IP00

5.2 Current/Voltage Technical Data



Note:

For all models, the Max Output current is guaranteed for $T_{\text{Heat-Sink}} < 85^{\circ}\text{C}$.

5.2.1 100V Models

Feature	Units	1/100	3/100	6/100	10/100	15/100	25/100
Minimum supply voltage	VDC	10					
Nominal supply voltage	VDC	85					
Maximum supply voltage	VDC	95					
Maximum continuous power output	W	80	235	470	800	1125	2000
Efficiency at rated power (at nominal conditions)	%	> 99					
Maximum output voltage		Up to 96% of DC bus voltage					
I _c , Amplitude sinusoidal/DC continuous current	A	1	3	6	10	15	25
Sinusoidal continuous RMS current limit (I _c)	A	0.7	2.1	4.2	7.1	10	17.7
Peak current limit	A	2 x I _c					

Table 1: 100V Models Technical Data

5.2.2 200V Models

Feature	Units	3/200	6/200	10/200
Minimum supply voltage	VDC	20		
Nominal supply voltage	VDC	170		
Maximum supply voltage	VDC	195		
Maximum continuous power output	W	485	975	1650
Efficiency at rated power (at nominal conditions)	%	> 99		
Maximum output voltage		Up to 96% of DC bus voltage		
I _c , Amplitude sinusoidal/DC continuous current	A	3	6	10
Sinusoidal continuous RMS current limit (I _c)	A	2.1	4.2	7.1
Peak current limit	A	2 x I _c		

Table 2: 200V Models Technical Data

5.2.3 R Type Models Operating at -40 to 62 °C (-40 to 143.6 °F)

Feature	Units	R80/80	R50/100	R70/100	R45/150	R15/200	R35/200
Minimum supply voltage	VDC	10	10	10	10	20	20
Nominal supply voltage	VDC	65	85	85	115	170	170
Maximum supply voltage	VDC	75	95	95	135	195	195
Maximum continuous Electrical power output	kW	5	4	5.6	5	2.5	5.6
Efficiency at rated power (at nominal conditions)	%	> 99					
Maximum output voltage		Up to 96% of DC bus voltage					
Amplitude sinusoidal/DC continuous current	A	80	50	70	45	15	35
Sinusoidal continuous RMS current limit (I _c)	A	56.5	35.3	49.5	32	10.6	24.7

Table 3: R Type Models (Operating at -40 to 62 °C) Technical Data

5.2.4 R Type Models Operating at -40 to 71 °C (-40 to 159.8 °F)

Feature	Units	R80/80	R50/100	R70/100	R45/150	R15/200	R35/200
Minimum supply voltage	VDC	10	10	10	10	20	20
Nominal supply voltage	VDC	65	85	85	115	170	170
Maximum supply voltage	VDC	75	95	95	135	195	195
Maximum continuous Electrical power output	kW	4.3	4	4.8	3.7	2.5	4.7
Efficiency at rated power (at nominal conditions)	%	> 99					
Maximum output voltage		Up to 96% of DC bus voltage					
Amplitude sinusoidal/DC continuous current	A	70	50	62	33	15	29
Sinusoidal continuous RMS current limit (Ic)	A	49.5	35.3	43.8	23.3	10.6	20.5

Table 4: R Type Models (Operating at -40 to 71 °C) Technical Data

5.3 Control Supply

Feature	Units	Details
Control supply input voltage for Safety	V	Isolated DC source: 12 to 60 V
24V Control supply input power consumption	Without Encoder	≤4
	With encoder up to 400mA@5V	≤6

5.4 Encoder Supply

Feature	Details
5V supply	400 mA

5.5 Product Features

5.5.1 Analog Input

Feature	Details	Resolution	Presence and No.
Analog Input	Differential ±10V	14-bits	1
	Single Ended 3.3V	12-bits	1

5.5.2 General Product Features

Main Feature	Details	Presence / No.
Feedback	Standard Port A, B, & C	√
Communication Option	USB	√
	EtherCAT <i>or</i>	√
	CAN	√
	RS232 TTL level	√

5.5.3 IO Features Module

Main Feature	Details	Presence / No.
STO	+5V Logic, Opto isolated	√
Digital Input	TTL 3.3V	6
Digital Output	TTL 3.3V	4

5.6 Environmental Conditions

You can guarantee the safe operation of the Platinum Bee by ensuring that it is installed in an appropriate environment. Section 5.6.1 describes the extended environmental conditions. However, the Functional Safety of the ExtrlQ series servo drives is certified according to the environmental conditions in section 5.6.2.



Warning:

During operation the Platinum Bee becomes hot to the touch (the heatsink and wires may heat up to 92 °C). Care should be taken when handling it.

5.6.1 ExtrlQ Conditions

Feature	Operation Conditions	Range
Operating ambient temperature		-40 °C to 71 °C (-40 °F to 159.8 °F) for all servo drives except for the R Type Models Operating at -40 to 62 °C (-40 to 143.6 °F) in section 5.2.3.
Storage temperature		-40 °C to +85 °C (-40 °F to +185 °F)
Altitude	Non-operating conditions	Unlimited
	Operating conditions	-400 m to 12,000 m (-1312 to 39370 feet)
Maximum Humidity	Non-operating conditions	Up to 95% relative humidity non-condensing at 35 °C (95 °F)
	Operating conditions	Up to 95% relative humidity non-condensing at 25 °C (77 °F), up to 90% relative humidity non-condensing at 42 °C (108 °F)
Vibration	Operating conditions	20 Hz to 2,000 Hz, 14.6 g

5.6.2 Functional Safety

Functional Safety of the ExtriQ series servo drives is certified according to the following environmental conditions.

Feature	Details
Operating ambient temperature	-40 °C to 71 °C (-40 °F to 159.8 °F) for all servo drives except for the R Type Models Operating at -40 to 62 °C (-40 to 143.6 °F) in section 5.2.3.
Storage temperature	-40 °C to +85 °C (-40 °F to +185 °F)
Maximum non-condensing humidity according to IEC60068-2-78	95%
Maximum Operating Altitude	2,000 m (6562 feet) It should be noted that servo drives capable of higher operating altitudes are available on request.
Mechanical Shock according to IEC60068-2-27	15g / 11ms Half Sine
Vibration according to IEC60068-2-6	5 Hz ≤ f ≤ 10 Hz: ±10mm 10 Hz ≤ f ≤ 57 Hz: 4G 57 Hz ≤ f ≤ 500 Hz:5G
Pollution Degree	Pollution Degree 1

5.7 Standards and Certifications

The following table describes the Main Standards of the Platinum Bee servo drive. For further details, refer to Chapter 22 in the [Platinum Safety Drive Manual](#).

5.7.1 Functional Safety

Standard	Item
IEC 61800-5-2:2017	Adjustable speed electrical power drive systems – Safety requirements – Functional
EN ISO 13849-1:2015	Safety of machinery — Safety-related parts of control systems.
EN 61508-1:2010	Functional safety of electrical/electronic/ programmable electronic safety-related systems
EN 61508-2:2010	Functional safety of electrical/electronic/ programmable electronic safety-related systems
EN 61508-3:2010	Functional safety of electrical/electronic/ programmable electronic safety-related systems
IEC 61784-3:2016	Functional Safety Filed Bus - FSOE

5.7.2 Electrical Safety

Specification	Details
IEC/EN 61800-5-1:2007	Adjustable speed electrical power drive systems Part 5-1: Safety requirements – Electrical, thermal and energy
UL 61800-5-1	Adjustable speed electrical power drive systems: Safety requirements – Electrical, thermal and energy
CSA C22.2 NO. 274-17	Adjustable speed drives

5.7.3 Electromagnetic Compatibility

Specification	Details
EN 61800-3:2004/A1:2011	Adjustable speed electrical power drive systems Part 3: EMC requirements and specific test methods
EN 61800-5-2: 2017 Annex E	Adjustable speed electrical power drive systems Part 5-2: Safety requirements – Functional

5.7.4 Environmental

Specification	Details
IEC60068-2-78	Damp heat, steady state
IEC60068-2-6	Vibration (sinusoidal)
IEC60068-2-2	Dry heat
IEC60068-2-27	Shock
IEC60068-2-1	Cold Test

5.7.5 Other Compliant Standards

For other compliant standards refer to the

[Platinum Safety Drive Manual Section 22.5](#) or refer to the Elmo website:

<https://www.elmomc.com/capabilities/standards-compliance/platinum-family/>

5.7.6 Dual Use

No export license is required for the Platinum Line products signified with the suffix Q in the Part Number.

The operating frequency of the Platinum Line products is “factory limited” to ≤ 599 Hz, and therefore complies with the EU Dual Use Regulation 428/2009, 3A225, and the US Dual Use regulation EAR ECCN# 3A225.

This statement applies to all identical specimens and will become invalid if a change is made in the firmware.

Chapter 6: Installation

The Platinum Bee must be installed in a suitable environment and properly connected to its voltage supplies and the motor.

6.1 Unpacking the Drive Components

Before you begin working with the Platinum Bee, verify that you have all of its components, as follows:

- The Platinum Bee servo drive
- The Elmo Application Studio (EASII) software and software manual

The Platinum Bee is shipped in a cardboard box with Styrofoam protection.

To unpack the Platinum Bee:

1. Carefully remove the servo drive from the box and the Styrofoam.
2. Check the drive to ensure that there is no visible damage to the instrument. If any damage has occurred, report it immediately to the carrier that delivered your drive.
3. To ensure that the Platinum Bee you have unpacked is the appropriate type for your requirements, locate the part number sticker on the top of the Platinum Bee. It looks like this:



4. Verify that the Platinum Bee type is the one that you ordered, and ensure that the voltage meets your specific requirements.
The part number at the top provides the type designation. Refer to the appropriate part number in the section Catalog Number at the beginning of the installation guide.

6.2 Over-Current and Short-Circuit Protection

A serial fuse or circuit breaker should be installed Rated for drive's continuous current rating.

PBEE -Mz-zXXX/YYYzz-z XXX = rated continues current [A]	Fuse	Circuit Breaker
1, 3, 6, 10, 15, 25	Slow blow	Type D
35, 45, 50, 70, 80	Fast Acting Class J	Type B

PL/CL protection: Peak and Continues Limitation

The peak current of servo drive limit for a given application is programmed to the parameter **PL[1]** amperes.
PL[1]: Value for peak current limit protection. Please refer to the "Platinum Administrative Guide".

6.3 Mounting the Platinum Bee

The Platinum Bee was designed for mounting on a printed circuit board (PCB) via 1.27 mm pitch 0.40 mm square pins, 0.508 mm square pin and 3.65 mm pitch 1.02 mm round pins. When integrating the Platinum Bee into a device, be sure to leave about 1 cm (0.4") outward from the heat-sink to enable free air convection around the drive. We recommend that the Platinum Bee be soldered directly to the board. If the PCB is enclosed in a metal chassis, we recommend that the Platinum Bee be screw-mounted to it as well to help with heat dissipation. The Platinum Bee has screw-mount holes on each corner of the heat-sink for this purpose – see below

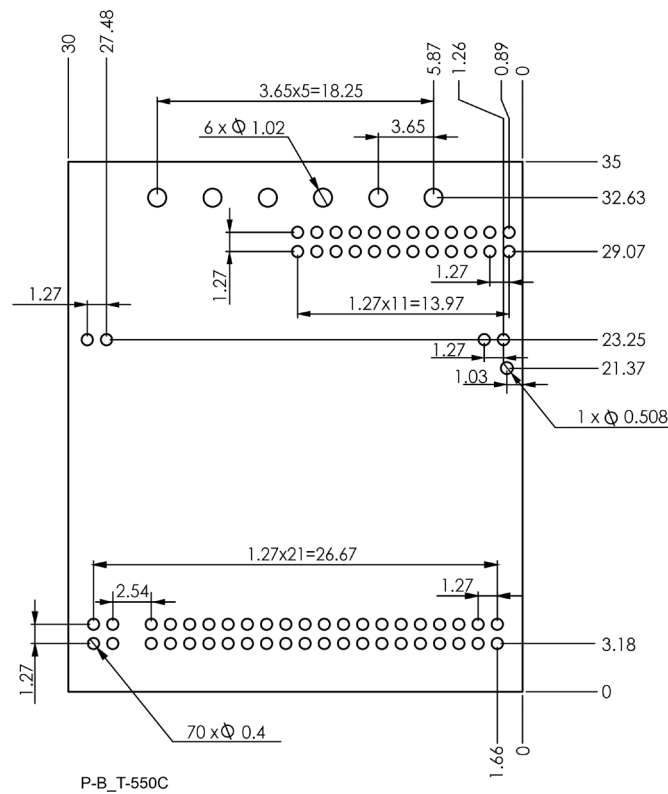

Figure 3: Platinum Bee Pins, Dimensions

6.3.1 Mounting Platinum Bee to an External Heatsink



Note: This feature is available only in model PBEE-Mz-zXXX/YYYzz-H.

The selected heat sink must be screwed to the lower surface of the Platinum Bee.

To mount the Platinum Bee to an external heat sink:

1. Mount the heat sink under the base of the Platinum Bee.
2. Place the Thermal foil (PN IMT-GTWIALHFLAT purchased from Elmo) between the lower surface of the servo drive, and the upper surface of the heat sink.
3. Use four M2.5 head cup Allen screws to secure the heat sink under the servo drive.
4. Tighten the screws to the relevant torque force applicable to an M2.5 stainless steel A2 screw.

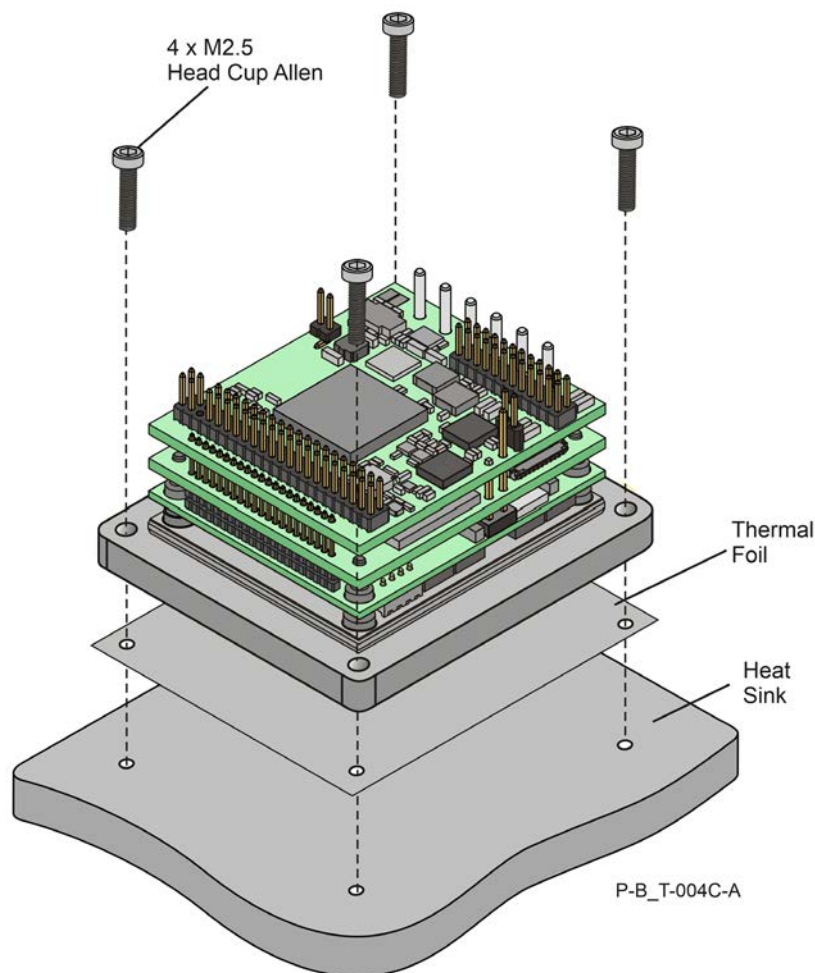

Figure 4: Mounting the Heat Sink and Thermal Foil to the Platinum Bee

Chapter 7: Connections

The Platinum Bee has 11 connectors (ports), as follows:

Port	Pins	Type	Function
FDB	2x12	1.27 mm pitch 0.40 mm sq.	Feedbacks
M3	1x1	3.65 mm pitch 1.02 mm round pins	Motor power output 3
M2	1x1		Motor power output 2
M1	1x1		Motor power output 1
PE	1x1		Protective earth
PR	1x1		Power output return
VP+	1x1		DC Positive power input
VL+	1x1	0.508 mm sq.	VL+
MAIN	2x21	1.27 mm pitch 0.40mm sq.	I/O, LEDs, STO, Communication
Extended IO	1x2	1.27 mm pitch 0.40mm sq.	Extended IO pins
3.3 V	1x2	1.27 mm pitch 0.40mm sq.	Available for EtherCAT and CAN versions Only for LEDS and Transformer

Connector Locations

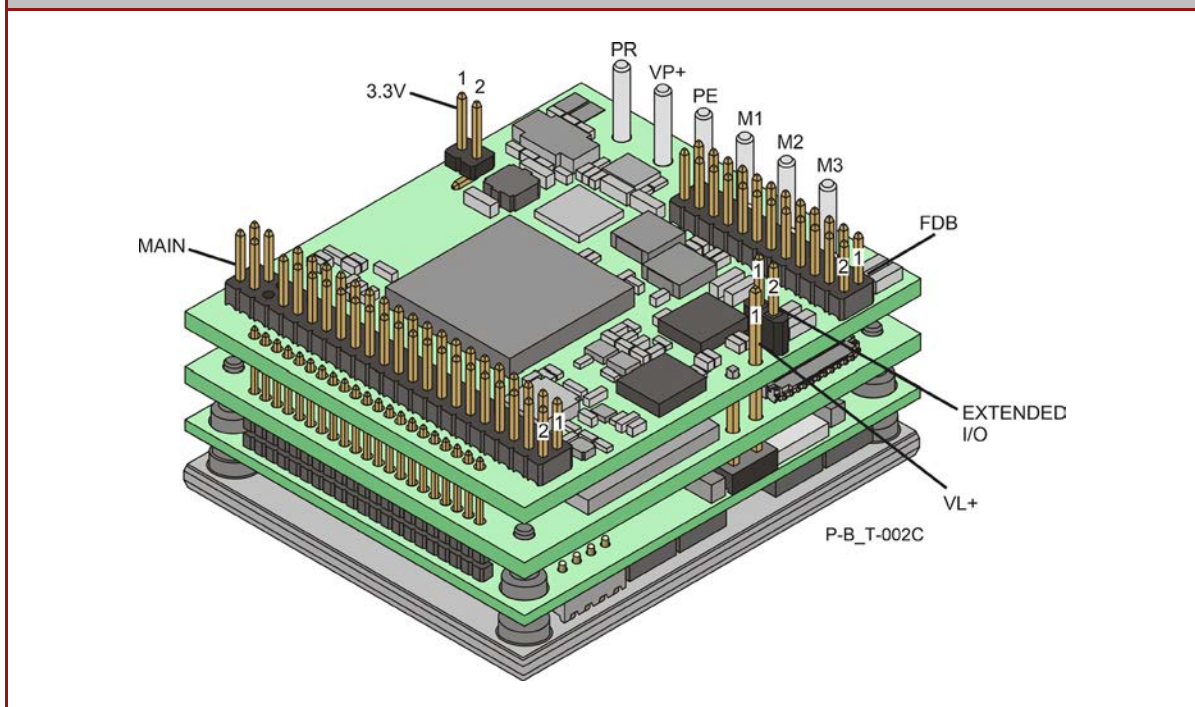

Table 5: EtherCAT Version Connector Types

7.1 Motor Power Pins

This section describes the Motor Power.

Pin	Function	Cable		Pin Positions
		Brushless Motor	Brushed DC Motor	
PE	Connection earth	Motor	Motor	
M1	Motor phase	Motor	N/C	
M2	Motor phase	Motor	Motor	
M3	Motor phase	Motor	Motor	

Table 6: Motor Power Pins

7.2 Main Power Pins

This section describes the Main Power supply connector.

The VDC isolated from the Mains DC power source is not included with the Platinum Bee.

Pin	Function	Cable	Pin Positions
VP+	DC Pos. Power input	Power	
PR	Power input return	Power	
PE	Protective earth	Power	

Table 7: Main Power Pins

7.3 Control Supply Pins

Connect the VL+ pin on the Platinum Bee in the manner described in the table below.

Pin	Signal	Function	Pin Positions
1	VL+	Control Supply Input	 <p>P-B_T-511C</p>
<p>Input range: 12VDC – 60VDC</p> <p>Power consumption:</p> <p>≤4 VA without external loading</p> <p>≤6 VA with full external loading</p>			

Table 8: Control Supply Pins

7.4 Feedback Pins (FDB)

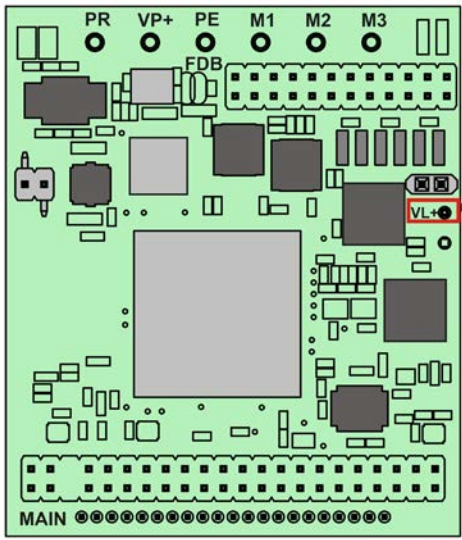
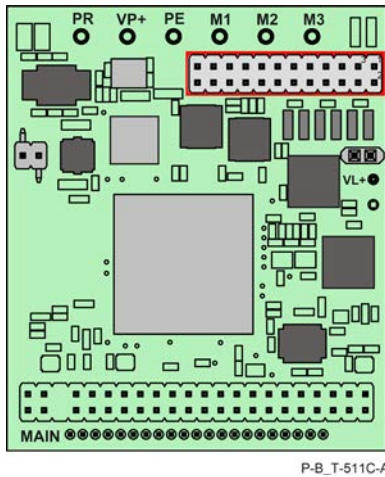

Feedback A/B/C, Digital Halls – see Chapter 11 in the [Platinum Safety Drive Manual](#).

FDB Pins

Pin (FDB)	Signal	Function
1	PortA_A+	Port A Channel A+
2	PortB_A-/Sine-	Port B Channel A-/Sine-
3	PortA_A-	Port A Channel A-
4	PortB_A+/Sine+	Port B Channel A+/Sine+
5	PortA_B+	Port A Channel B+
6	PortB_B-/Cosine-	Port B Channel B-/Cosine-
7	PortA_B-	Port A Channel B-
8	PortB_B+/Cosine+	Port B Channel B+/Cosine+
9	PortA_INDEX+	Port A Channel Index+
10	PortB_INDEX-/Analog_Index-	Port B Channel Index-/Analog Index-
	RESOLVER_OUT-	Vref complement
11	PortA_INDEX-	Port A Channel Index-
12	PortB_INDEX+/Analog_Index+	Port B Channel Index+/Analog Index+
	RESOLVER_OUT+	Vref
13	HALL A	Hall sensor A input
14	PortC_A-	Port C Buffered Channel A-
15	HALL B	Hall sensor B Input
16	PortC_A+	Port C Buffered Channel A+
17	HALL C	Hall sensor C Input
18	PortC_B-	Port C Buffered Channel B- output / Dir-
19	+5V	Encoder +5V supply with a total allowable maximum consumption of 400mA
20	PortC_B+	Port C Buffered Channel B+ output / Dir+
21	COMRET	Common return
22	PortC_INDEX-	Port C Buffered Channel INDEX- output
23	COMRET	Common return
24	PortC_INDEX+	Port C Buffered Channel INDEX+ output

Table 9: FDB Connector – Feedback

7.5 Main Pins (MAIN)

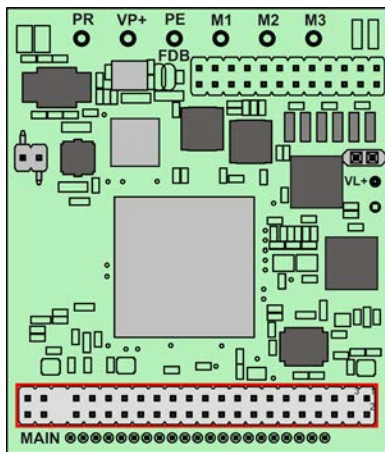

P-B_T-511C-E

- USB– see section 16.10.1 in the [Platinum Safety Drive Manual](#)
- RS-232– see section 16.10.3 in the [Platinum Safety Drive Manual](#)
- EtherCAT– see section 16.10.2 in the [Platinum Safety Drive Manual](#)
- CAN– see section 9.11.4 in this manual
- Analog– see section 16.8 in the [Platinum Safety Drive Manual](#)
- Regular Digital IO– see section 13.4 in the [Platinum Safety Drive Manual](#)
- STO– see section 16.5 in the [Platinum Safety Drive Manual](#)

MAIN Pins

Pin (MAIN)	Signal	Function	
1	USB_VBUS	USB VBUS 5V Detector	
2	USBD+	USB_P line	
3	RS232_RX /SB_OUT	There are two options for this pin: Option 1: TTL RS232 receive (default) Option 2: Serial Bus output for extended I/O (refer to MAN-P-Safety Drive Manual) This option is only available for EtherCAT	
4	USBD-	USB_N line	
5	PHY_IN_LINK_ACT	Indicates EtherCAT IN	
	CANL	CAN_L BUS Line(dominant low)	
6	PHY_OUT_LINK_ACT	Indicates EtherCAT OUT LINK/Ethernet LINK input	
7	PHY_IN_SPEED	Indicates EtherCAT IN	
	CANH	CAN_H BUS Line (dominant high)	
8	PHY_OUT_SPEED	Indicates EtherCAT OUT Speed/Ethernet Speed input	
9	LED_ET_ERR	EtherCAT status LED Error	
10	LED_ET_RUN	EtherCAT status LED Run	
11	RS232_TX /SB_IN	There are two options for this pin: Option 1: TTL RS232 transmit (Default) Option 2: Serial Bus IN for extended I/O (refer to MAN-P-Safety Drive Manual) This option is only available for EtherCAT	
12	ANALOG2+	Analog input 2	There is no ANARET (analog return) pin. Instead the COMRET pin used.
13	COMRET	Common return	
14	COMRET	Common return	
15	ANALOG1+	Analog input 1	There is no ANARET (analog return) pin. Instead the COMRET pin used.
16	ANALOG1-	Analog input 1 complement	
17	IN6	Programmable digital input 6 (connected to COMRET) (3.3V logic level)	

Pin (MAIN)	Signal	Function
18	IN5	Programmable digital input 5 (connected to COMRET) (3.3V logic level)
19	IN4	Programmable digital input 4 (connected to COMRET) (3.3V logic level)
20	IN3	Programmable digital input 3 (connected to COMRET) (3.3V logic level)
21	IN2	Programmable digital input 2 (connected to COMRET) (3.3V logic level)
22	IN1	Programmable digital input 1 (connected to COMRET) (3.3V logic level)
23	LED1	Bi-color indication output 1 (Cathode) Internal Resistor 1K Ω
24	LED2	Bi-color indication output 2 (Cathode) Internal Resistor 1K Ω
25	OUT4	Programmable output 4 (connected to COMRET) (3.3V logic level)
26	OUT2	Programmable output 2 (connected to COMRET) (3.3V logic level)
27	OUT3	Programmable output 3 (connected to COMRET) (3.3V logic level)
28	OUT1	Programmable output 1 (connected to COMRET) (3.3V logic level)
29	COMRET	Common return
30	COMRET	Common return
31	EtherCAT_IN_RX+	EtherCAT IN RX+ Line
32	EtherCAT_IN_TX+	EtherCAT IN TX+ Line
33	EtherCAT_IN_RX-	EtherCAT IN RX- Line
34	EtherCAT_IN_TX-	EtherCAT IN TX- Line
35	EtherCAT_OUT_RX+/Ethernet_RX+	EtherCAT OUT/Ethernet RX+ Line
36	EtherCAT_OUT_TX+/Ethernet_TX+	EtherCAT OUT/Ethernet TX+ Line
37	EtherCAT_OUT_RX-/Ethernet_RX-	EtherCAT OUT/ Ethernet RX- Line
38	EtherCAT_OUT_TX-/Ethernet_TX-	EtherCAT OUT/ Ethernet TX- Line
39	Not connected	
40	Not connected	
41	STO1	STO 1 input, opto isolated from control (COMRET)
42	STO_RET	STO signal return. The two digital STO inputs are optically isolated from the other parts of the drive.
43	STO2	STO 2 input, opto isolated from control (COMRET)
44	STO_RET	STO signal return. The two digital STO inputs are optically isolated from the other parts of the drive.

Table 10: MAIN Pins – I/O, STO, Analog, LEDs, Communication



Note: EtherCAT OUT port can be configured to an Ethernet Port.

7.6 Drive Status Indicator

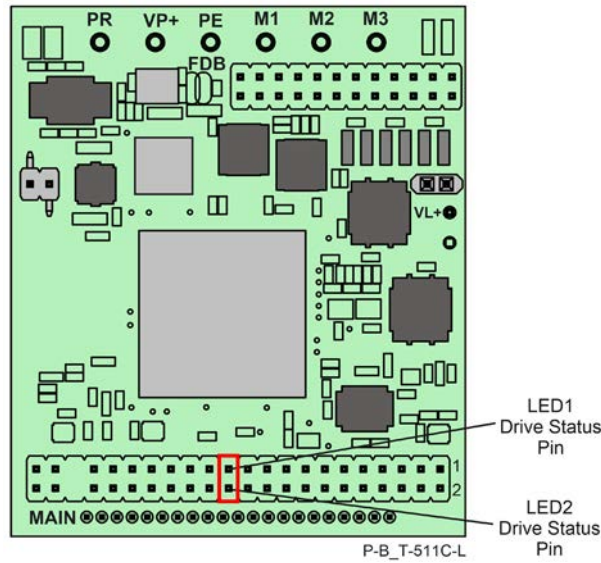
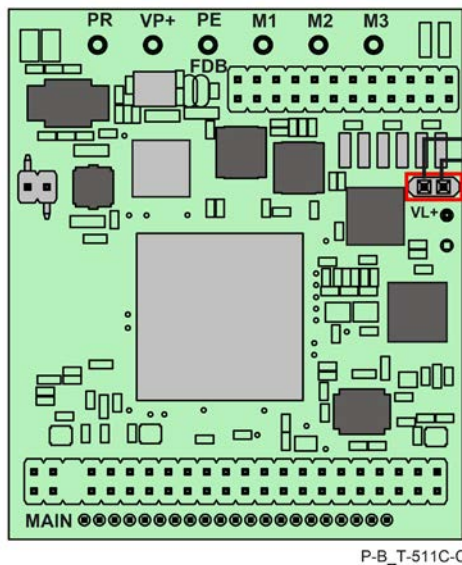

Figure 5: Platinum Bee Drive Status Indicator pins

Figure 5 shows the position of the Drive Status Indicator pin which is used for immediate indication of the Initiation and Working states.

7.7 Extended IO Pins



Extended Digital IO— see section 16.9 in the [Platinum Safety Drive Manual](#)

For application of extended features refer to the **Application Note IO Extended Features**

Extended IO Pins

Pin (Extended IO)	Signal	Function
1	SB_Clock	Serial Bus_Clock (9.375Mhz) for extended IO
2	SB_Load	Serial Bus Load for extended IO

Table 11: Extended IO Pins

7.8 3.3V Pins

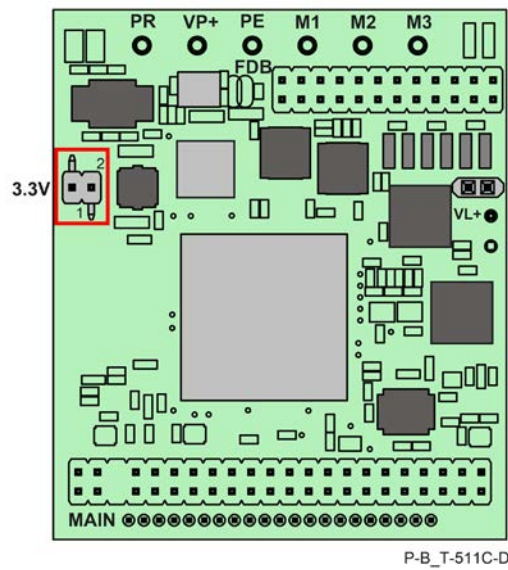

3.3V Pins



Pin (3.3V)	Signal	Function
1	3.3V	3.3 V supply voltage for EtherCAT LEDs
2	3.3V	3.3 V supply voltage for EtherCAT LEDs

Table 12: 3.3V Pins

Chapter 8: Wiring

8.1 Wiring Legend

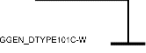
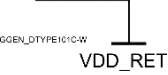
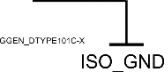
The following table legend describes the wiring symbols detailed in all installation guides.

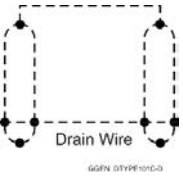
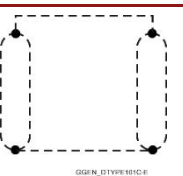
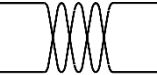
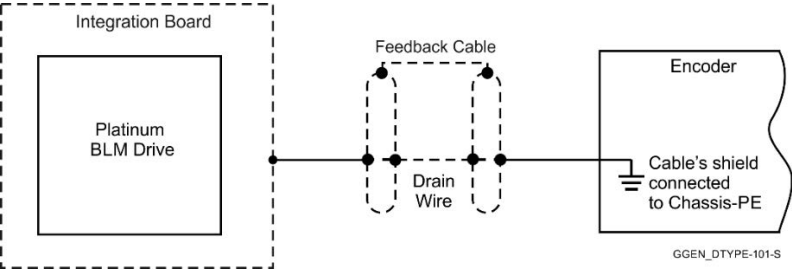
Wiring Symbol	Description
	Earth connection (PE)
 GGEN_DTYPE101C-W	User Side: This symbol signifies that any type of grounding may be used on the user side
 GGEN_DTYPE101C-W VDD_RET	VDD Return
 GGEN_DTYPE101C-X ISO_GND	Isolated Ground
 GGEN_DTYPE101C-C PR	Power Return
 GGEN_DTYPE101D-S	COMRET Common at the Drive
 GGEN_DTYPE101D-S Drain Wire	Shielded cable with drain wire. The drain wire is a non-insulated wire that is in direct contact with the braid (shielding). Shielded cable with drain wire significantly simplifies the wiring and earthing.
 GGEN_DTYPE101D-E	Shielded cable braid only, without drain wire.
 GGEN_DTYPE101D-F	Twisted-pair wires
 GGEN_DTYPE-101-S Encoder Earthing. The cable's shield is connected to the chassis (PE) in the connector. The servo drive shield is connected to Earth.	

8.2 The Platinum Bee Connection Diagrams

8.2.1 EtherCAT Connection Diagram

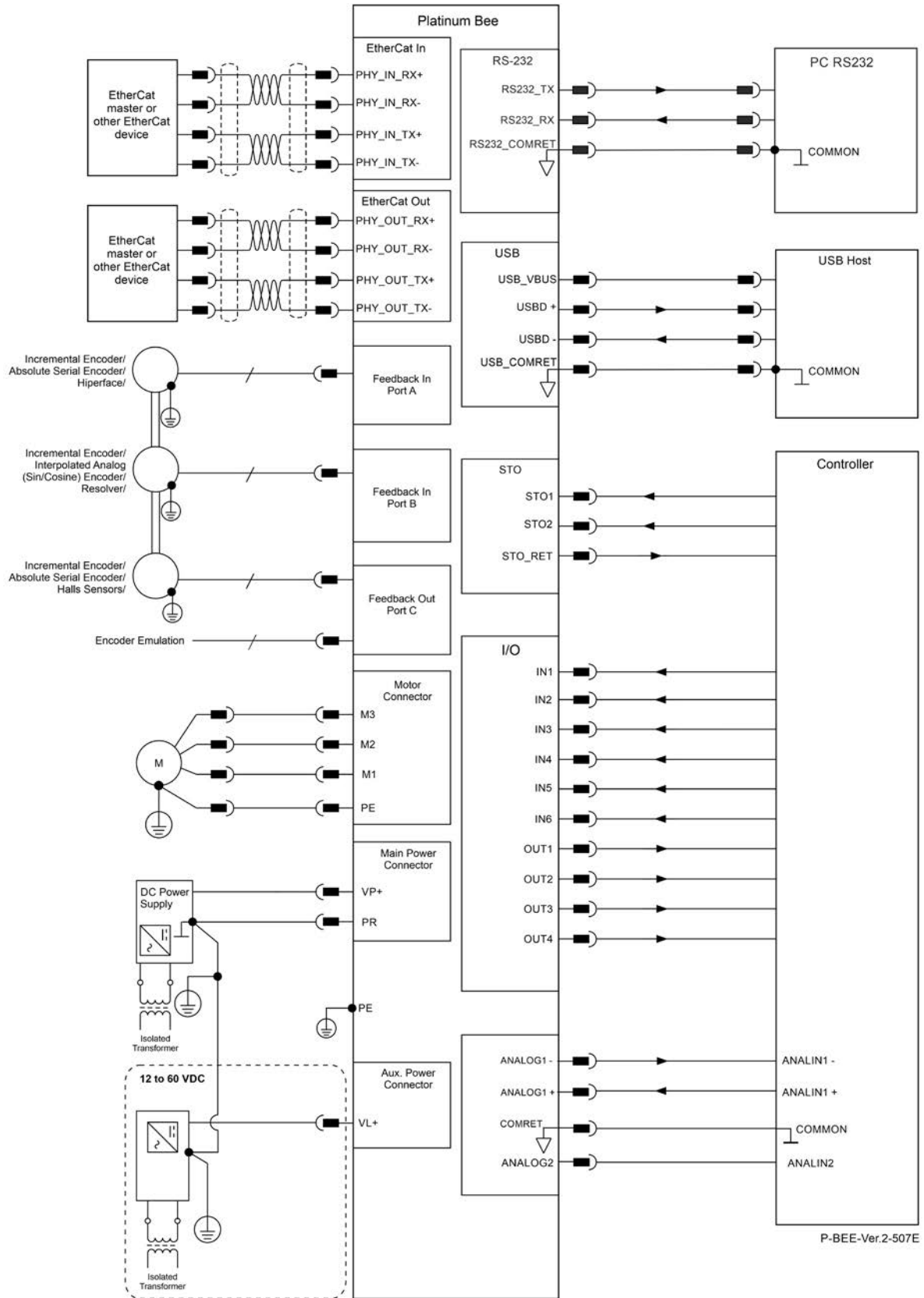
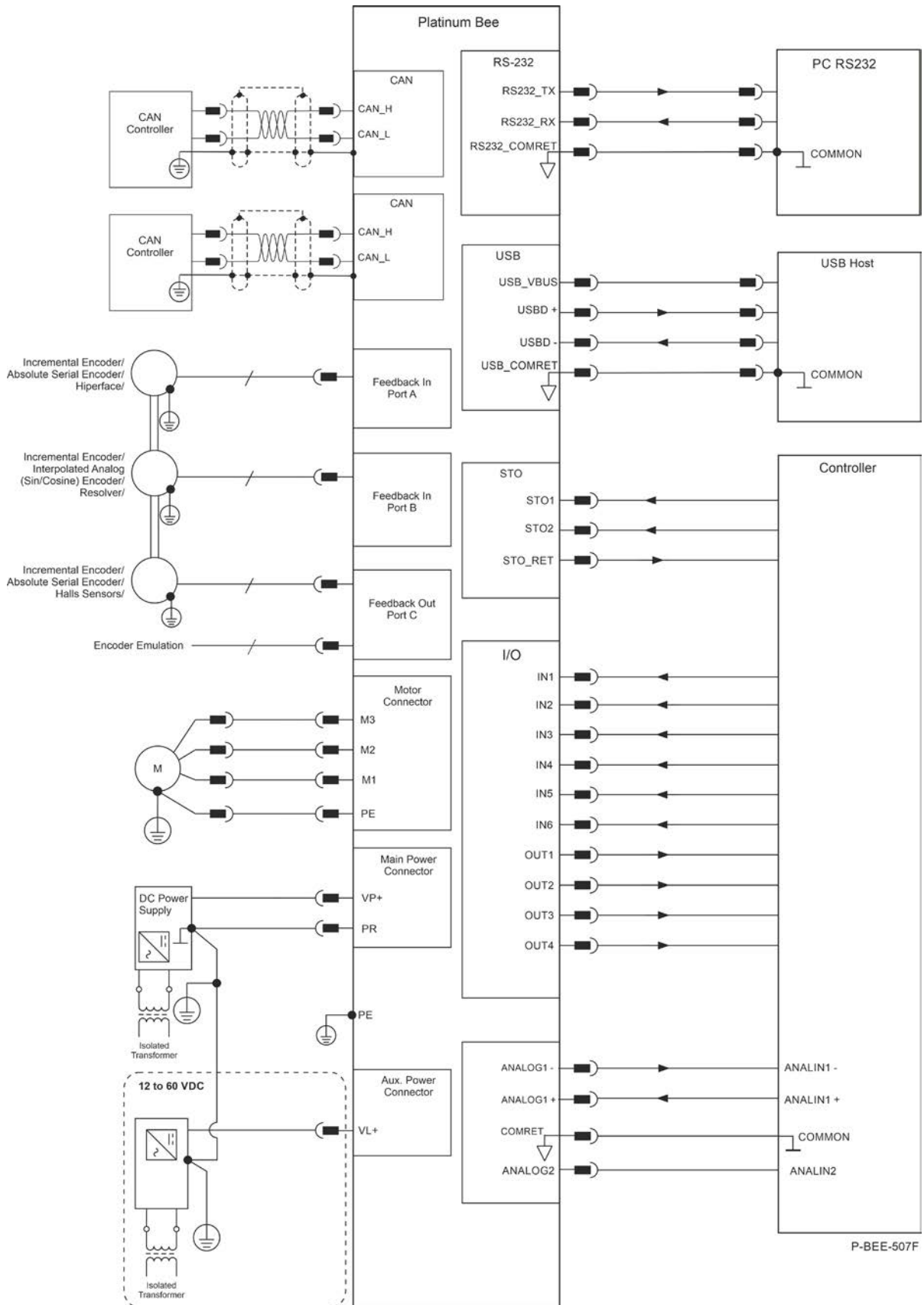

Figure 6: The Platinum Bee EtherCAT Connection Diagram

8.2.2 CAN Connection Diagram



P-BEE-507F

Figure 7: The Platinum Bee CAN Connection Diagram

8.3 Integrating the Platinum Bee on a PCB

The Platinum Bee is designed to be mounted on a PCB by soldering its pins directly to the PCB. Refer to Chapter 16 in the [Platinum Safety Drive Manual](#) for further information.

8.3.1 Power Returns (PR)

In the Platinum Bee, the power stage and control stage are internally connected, and the negative node of the DC power bus is designates as PR.

The maximum realistic Power Return is achieved using a plane, which connects between the Platinum Drive and the power source. The impedance on this plane must be as low as possible to reduce the impedance between the “Grounds”. This effectively reduces the levels of common mode differences, interferences, EMI etc.

8.3.2 Common Return (COMRET)

For details of the COMRET, refer to section 16.1.4 in the [Platinum Safety Drive Manual](#).

8.3.3 Earth Connection (PE)

The PE (Earth connection) terminal is connected internally in the drive to the Platinum Bee’s chassis (heat-sink) which serves as an EMI common plane. Any other assembly metallic parts (such as the chassis) should also be connected to the PE.

Under normal operating conditions, the PE trace carries no current. The only time these traces carry current is under unusual conditions (such as when the device has become a potential shock or fire hazard while conducting external EMI interferences directly to ground). When connected properly the PE trace prevents these hazards from affecting the drive.

8.3.4 Power Return (PR), Common Return (COMRET) and Earth Connections (PE)

Safety regulations (UL61800-5-1, IEC61800-5-1, and UL508C) require that the servo drive, as a “stand alone”, must withstand breakdown voltages of 2KV for the 200V models, and 1.7KV for the 100V models, between PE to PR. However, the connections between PE to PR and the COMRET are essential for the safe operation of the servo drive. Therefore, the following topology must be used:

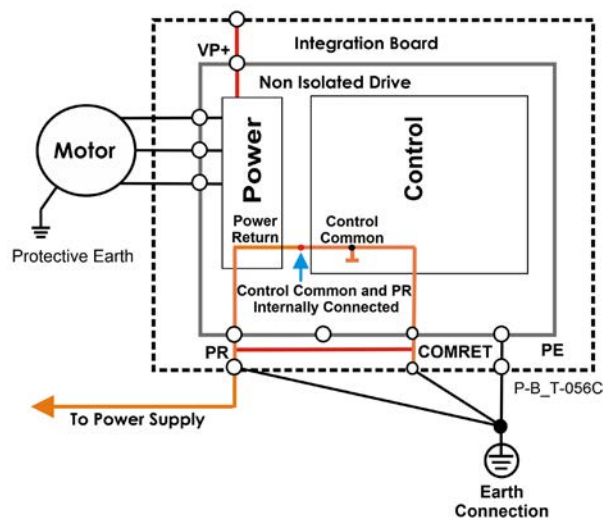

Figure 8: Platinum Bee Earth Connections

The connections to PE are essential, but must be done externally to the integration board.

The COMRET should be connected to the PR in the Integration Board.

8.4 Logic and Control Cabling and Wiring

For functional safety applications, shielded and twisted wires should be used.

8.4.1 Feedback Ports, VL, RS232, RS422, Analog Input, USB

For short distances between the drive and control, 0.5 to 1.0 m wires can be used and shielding is not required. For longer distances than 1.0 m and/or high EMI environment, shielded and twisted wires should be used. Drain wires should be connected to Elmo COMRET.

8.4.2 Digital Inputs/Outputs, STO

Wires can be always used, no need for twisting, no need for shielding.

8.4.3 EtherCAT and CAN Communications

Always use CAT5e cables.

8.5 Power Conductors PCB layout

The PCB virtually divided into two zones; Power Zone, and Control & Communication Zone.

- **Power Zone** - This area is dedicated to Power conductors only: VP+, PR, PE, VL+, and motor leads.
- **Control and Communication Zone** - This area of the PCB is dedicated to Control low level signals.

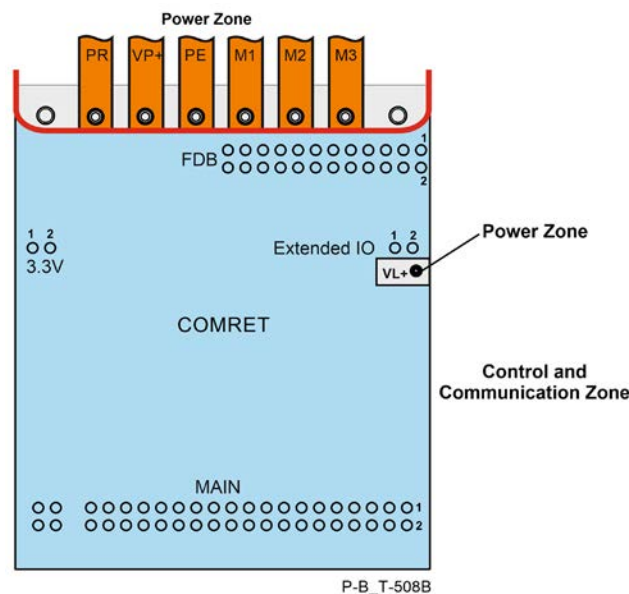

Figure 9: Platinum Bee EtherCAT Power Conductors PCB layout

For more details, refer to section 16.2.2 in the [Platinum Safety Drive Manual](#).

8.6 Motor Power (M1)

This section describes the Motor Power.

For full details refer to section 16.3 in the [Platinum Safety Drive Manual](#).

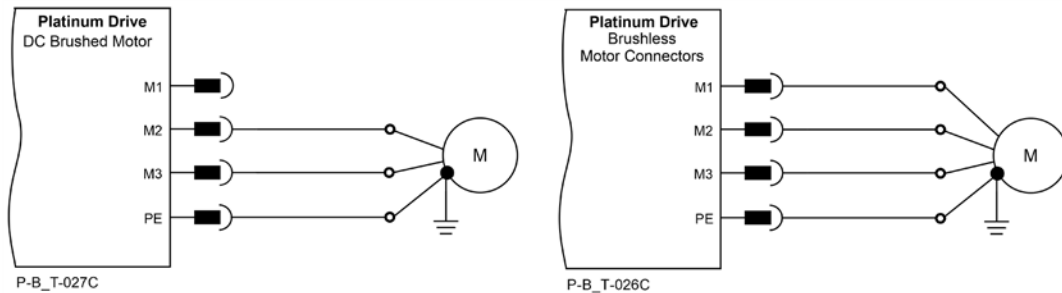

Figure 10: Brushed and Brushless Motor Power Connection Diagram

8.6.1 Connections

1. Ensure that the motor chassis is properly earthed.
2. Connect the appropriate wire from the Motor Power cables to the M1, M2, M3, and PE terminals on the Platinum Bee.

Make sure not to bundle the wires.

The phase connection is arbitrary as Elmo Application Studio (EAS II) will establish the proper commutation automatically during setup. When tuning a number of drives, you can copy the setup file to the other drives and thus avoid tuning each drive separately. In this case the motor-phase order must be the same as on the first drive.

3. For high EMI environment, it is highly recommended to use a 4-wire shielded (not twisted) cable for the motor connection. The gauge is determined by the actual RMS current consumption of the motor.

Connect the cable shield to the closest ground connection at the motor end.

For better EMI performance, the shield should be connected to Earth Connection (heat sink mounting holes).

8.7 Main Power and Control Connector

This section describes the Main Power and the Control supply connector.

8.7.1 Main Power

The VDC isolated from the Mains DC power source is not included with the Platinum Bee.

Connect the DC power cable to the VP+ and PR terminals on the main power connector.

To connect the Platinum Bee to the DC power source:

1. The source of the VDC power supply must be isolated from the Mains.
2. Verify that the rectified VDC is indeed within the range of the drive.
3. Connect the VP+ and PR wires to the terminals on the servo-drive.
It is highly recommended to twist the two DC main power cables at intervals of 10 cm.
4. Connect the PE to the closest earth connection near the power supply.
5. Connect the PR to the closest earth connection near the power supply.
6. Before applying power, first verify the polarity of the connection.

8.7.2 Control Supply Connections

To connect the VL+ pin on the Platinum Bee, to the control supply:

1. The source of the control supply must be isolated from the Mains.
2. Connect the return (common) of the control supply source to the closest earth connection near the control supply source.
3. Connect the VL+ wire to the terminals on the servo-drive.
For short distances between the drive and control, 0.5 to 1.0 m wires can be used and shielding is not required. For longer distances than 1.0 m and/or high EMI environment, shielded and twisted wires should be used. Drain wires should be connected to Elmo COMRET.
4. Before applying power, first verify the polarity of the connection.

8.7.2.1 Dual Power Supply Topology

Two DC power sources are required for functional safety:

- Main power isolated from the Mains
 - Main power 20 to 195VDC for 200V module
 - Main power 10 to 135VDC for 150V module
 - Main power 10 to 95VDC for 100V module
 - Main power 10 to 75VDC for 80V module
- Isolated Power supply maximum **60V for the logic**

8.7.2.1.1 Ordinary Option

This option describes an Ordinary power supply for Servo drives with sufficient internal capacitance and shunt regulator to handle power flow in both directions to-and-from the motor. The following figure describes this connection of main power and control power.

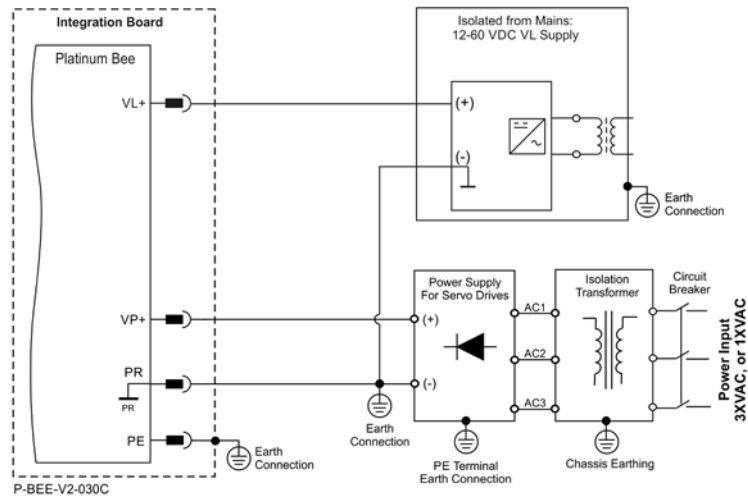

Figure 11: Ordinary Option: Separate VP and VL Power Supplies Connection Diagram

The (+) of the control power supply is connected to the VL+ terminal, while the (-) of the control power supply is connected directly to the (-) of the DC bus power supply. This connection avoids high current ground loops due to poor wiring (Figure 11).

8.7.2.1.2 SMPS Option

This option describes a topology with a main power without regeneration, but with limited Braking capabilities dependent on additional capacitance.

The $C_{external}$ can be mounted on the Integration Board if there are no space limitations.

Minimum capacitance of the Power supply: $C_{external} > \text{“Drive’s Rated Current”} * 20\mu F$

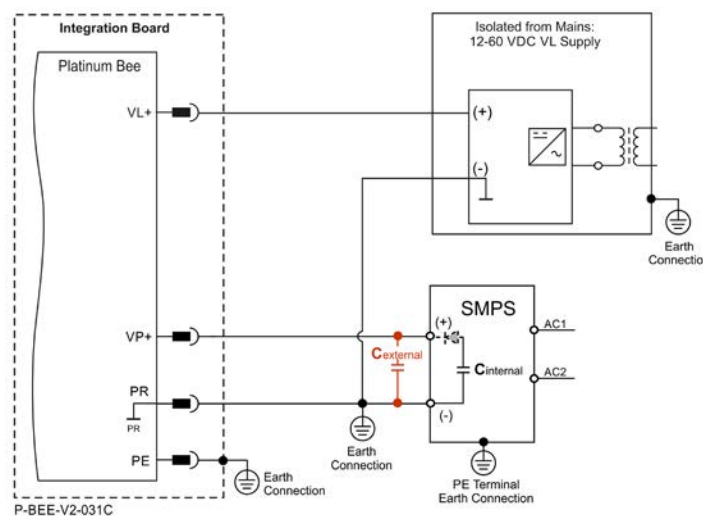

Figure 12: SMPS Option: Separate VP and VL Power Supplies Connection Diagram

The (+) of the control power supply is connected to the VL+ terminal, while the (-) of the control power supply is connected directly to the (-) of the DC bus power supply. This connection avoids high current ground loops due to poor wiring (Figure 12).

8.8 Feedback

Refer to Chapter 11 and section 16.6 Feedback, in the Platinum Safety Drive Manual for details, specification, and connections of the Feedback for safety.



Important:

It should be noted that throughout the Feedback section the following applies:

For short distances between the drive and control, 0.5 to 1.0 m wires can be used and shielding is not required. For longer distances than 1.0 m and/or high EMI environment, shielded and twisted wires should be used. Drain wires should be connected to Elmo COMRET.

8.8.1 Feedback Port A

Port A supports the following sensor inputs as described in the table below:

- Incremental Encoder or absolute serial Encoder
- Differential pulse-width modulation (PWM) signal input
- Differential Pulse & Direction signal inputs

Pin (FDB Connector) Port A	Incremental Encoder	Absolute Serial Encoder
Signal	Function	Function
1	Channel A +	Absolute encoder clock+
3	Channel A -	Absolute encoder clock-
5	Channel B+	Absolute encoder data+
7	Channel B -	Absolute encoder data -
9	Index+	
11	Index-	
19	Encoder +5V supply	
21, 23	Common return	

8.8.1.1 Incremental Encoder

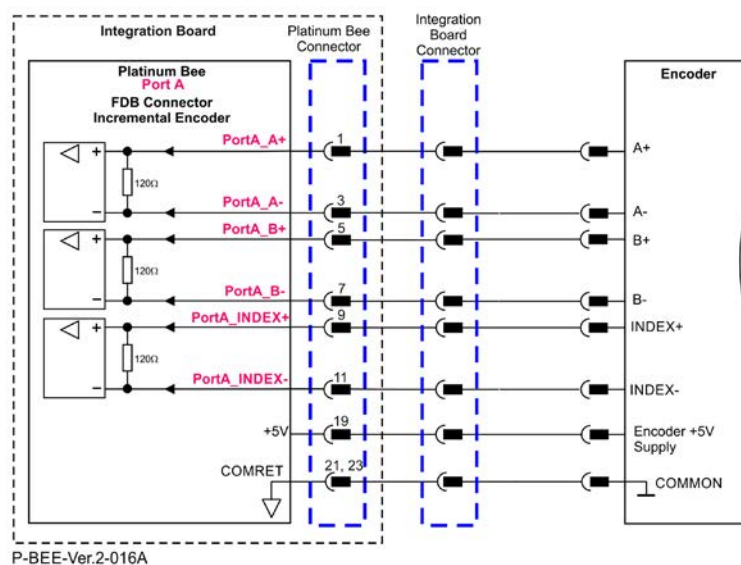

Figure 13: Port A Incremental Encoder Input – Recommended Connection Diagram

8.8.1.2 Absolute Serial Encoder

The following Absolute Encoder types are supported:

- EnDat 2.2
- Biss C and Biss B
- SSI
- Hiperface

The following is the diagram connection of the EnDat, Biss, SSI:

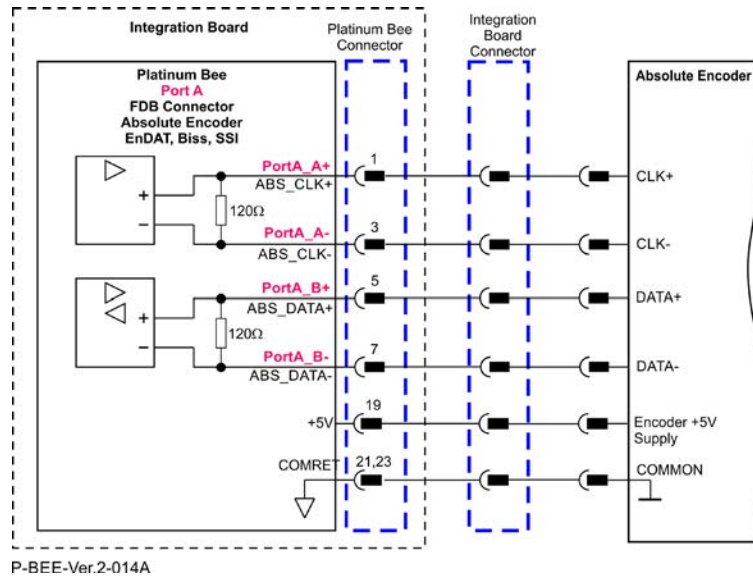

Figure 14: Absolute Serial Encoder – Recommended Connection Diagram for Endat, Biss, SSI

8.8.1.3 Hiperface

The following figure describes the connection diagram.

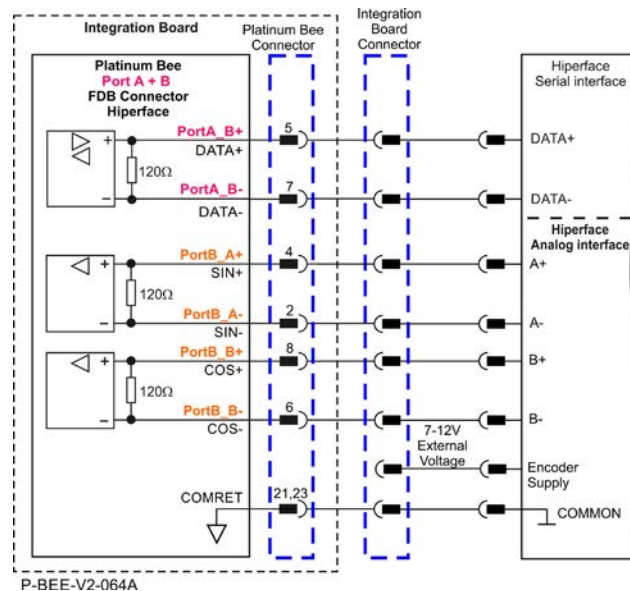

Figure 15: Absolute Serial Encoder – Recommended Connection Diagram for Stegmann Hiperface



Note:

You cannot use the Hiperface encoder for functional safety; the Hiperface encoder requires an external voltage supply of 7V to 12V.

8.8.2 Feedback Port B

Port B supports any of the following sensors described in the table:

- Incremental Encoder, interpolated analog Encoder

Or

- Resolver (separate hardware option)

Differential PWM signal input can be connected to port B

Pin (FDB Connector) Port B	Incremental Encoder	Interpolated Analog Encoder	Resolver
Signal	Function	Function	Function
	PBEE-Mz-XXX/YYYzE-z		PBEE-Mz-XXX/YYYzR-z
2	PortB_A-	Channel A -	Sine-
4	PortB_A+	Channel A+	Sine+
6	PortB_B-	Channel B-	Cosine-
8	PortB_B+	Channel B+	Cosine+
10	PortB_INDEX-	Channel_Index-	RESOLVER_OUT-Vref complement f= 1/TS, 50 mA Maximum
12	PortB_INDEX+	Channel_Index+	RESOLVER_OUT+ Vref f=1/TS, 50 mA Max.
19	+5V	Encoder +5V supply	
21, 23	COMRET	Common return	

8.8.2.1 Incremental Encoder

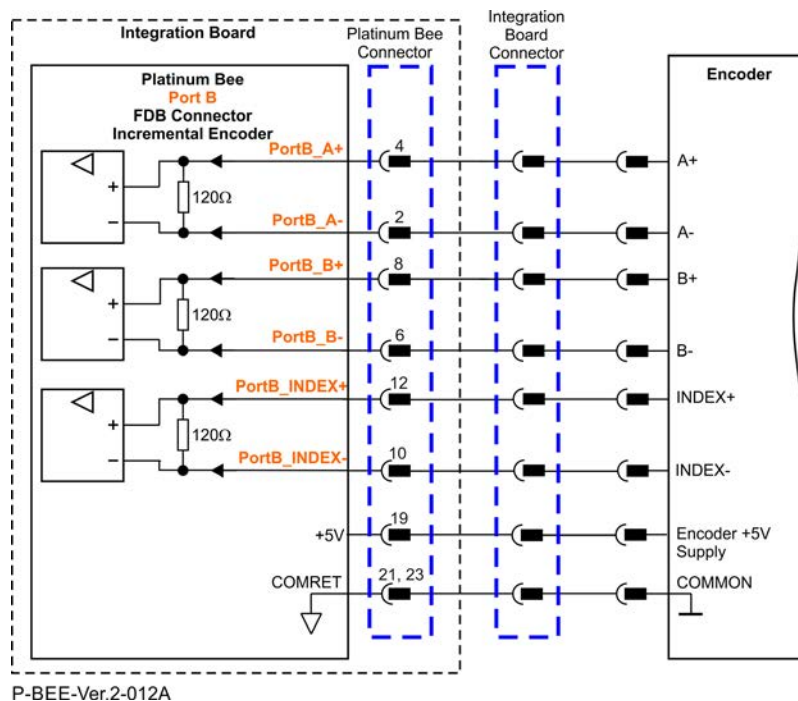

Figure 16: Port B Incremental Encoder Input – Recommended Connection Diagram

8.8.2.2 Interpolated Analog (Sine/Cosine) Encoder

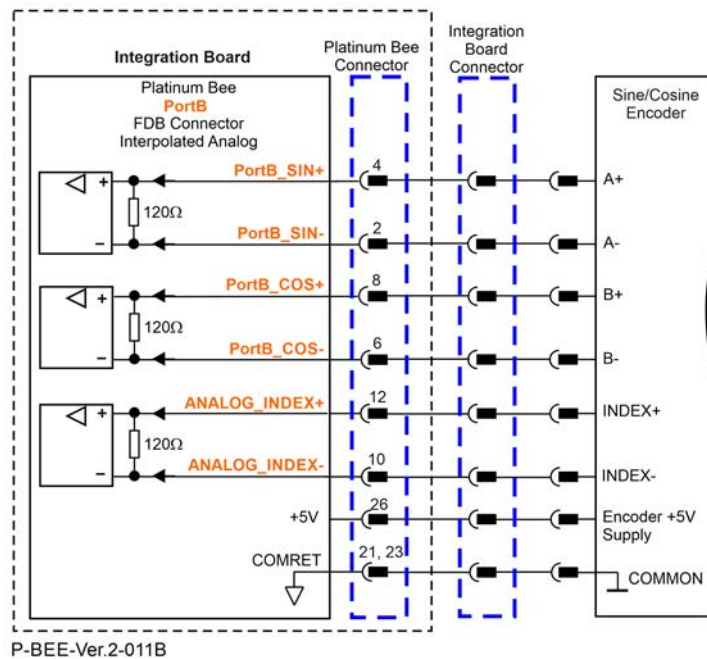

Figure 17: Port B - Interpolated Analog Encoder Connection Diagram

8.8.2.3 Resolver

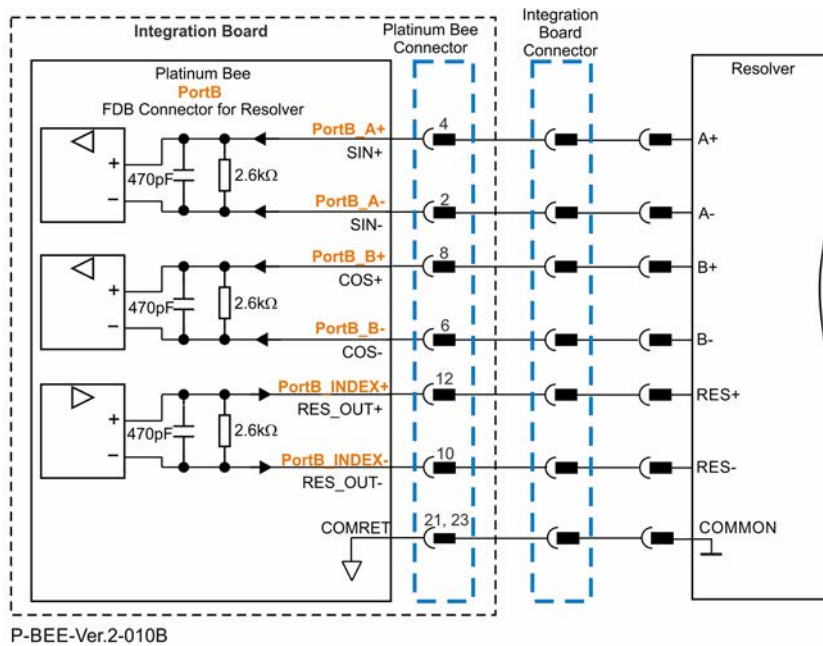

Figure 18: Port B – Resolver Connection Diagram

8.8.3 Feedback Port C

Port C provides the following as described in the table below:

- Incremental Encoder feedbacks
- Absolute Serial Encoder feedbacks
- Emulated Encoder output derived from port A, port B feedback inputs, or from internal variables
- Hall Sensors

Pin (FDB Connector) Port C		Incremental Encoder	Absolute Serial Encoder	Emulated Encoder
Signal		Function	Function	Function
13	HALL A	Hall A Input		
15	HALL B	Hall B Input		
17	HALL C	Hall C Input		
14	PORTC_A-	Channel A-	Absolute encoder clock-	Emulated Output A-
16	PORTC_A+	Channel A+	Absolute encoder clock+	Emulated Output A+
18	PORTC_B-	Channel B-	Absolute encoder data -	Emulated Output B-
20	PORTC_B+	Channel B+	Absolute encoder data+	Emulated Output B+
22	PORTC_INDEX-	Index -	Reserved	Emulated Output Index-
24	PORTC_INDEX+	Index+	Reserved	Emulated Output Index+
19	+5V	Encoder +5V supply		
21, 23	COMRET	Common return		

8.8.3.1 Incremental Encoder

The following Incremental Encoder types are supported:

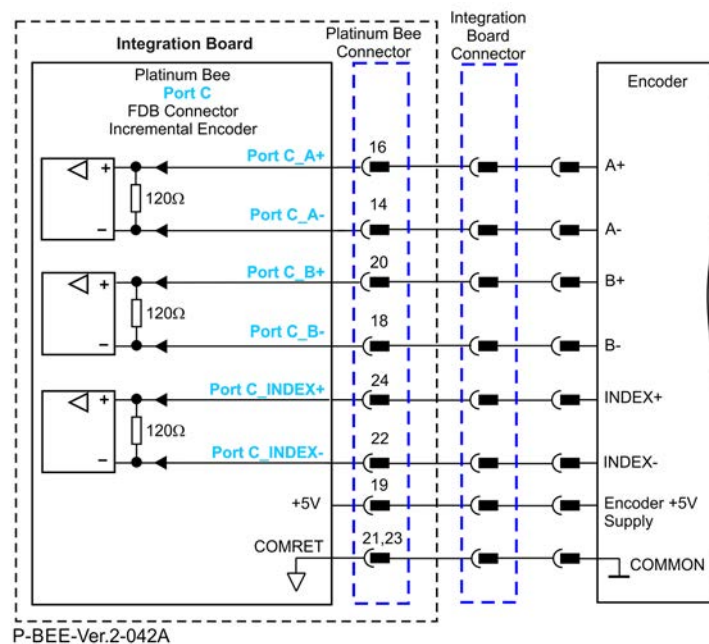

Figure 19: Port C Incremental Encoder Input – Recommended Connection Diagram

8.8.3.2 Absolute Serial Encoder

Port C supports the following ABS feedback:

- EnDat 2.2
- Biss C and Biss B
- SSI
- Panasonic, Tamagawa
- Sanyo

The following is the diagram connection of the EnDat, Biss, SSI:

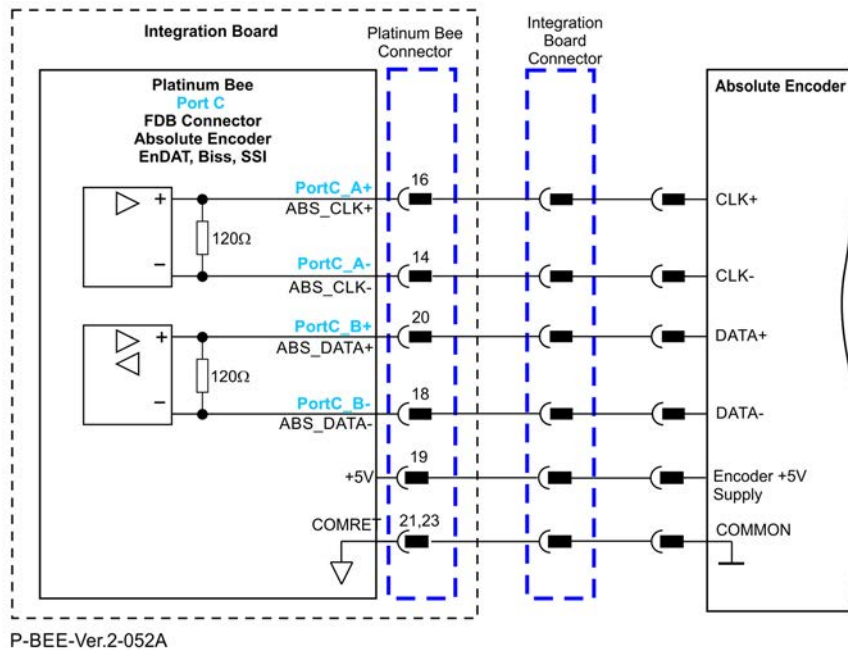

Figure 20: Absolute Serial Encoder – Recommended Connection Diagram for EnDat, Biss, SSI

The following is the feedback diagram connection for Panasonic, Tamgawai, Sanyo-Danki:

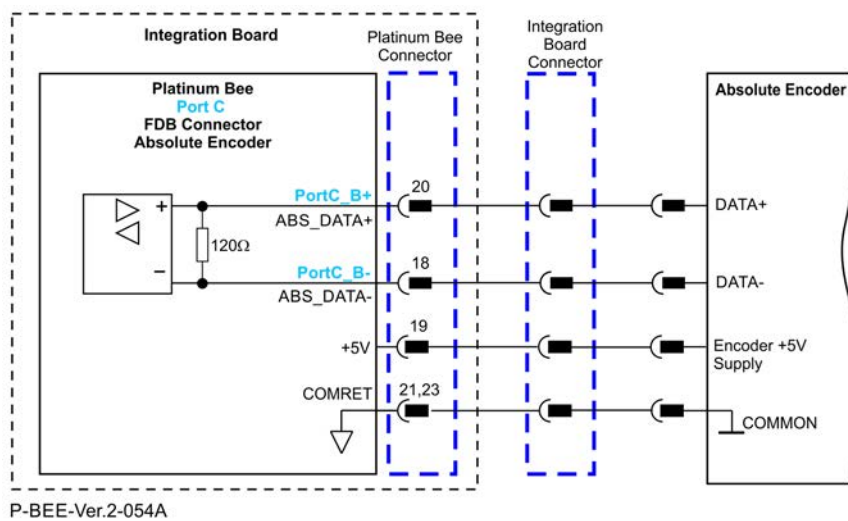

Figure 21: Absolute Serial Encoder – Recommended Connection Diagram for Panasonic, Tamgawai, Sanyo-Danki

8.8.3.3 Emulated Encoder Output

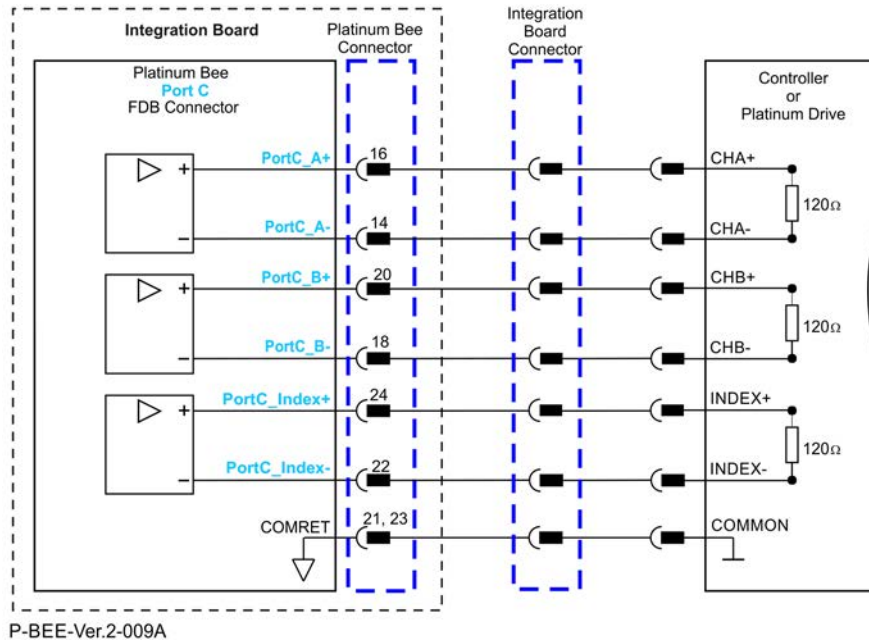

Figure 22: Emulated Encoder Differential Output – Recommended Connection Diagram

8.8.4 Feedback - Hall Sensors

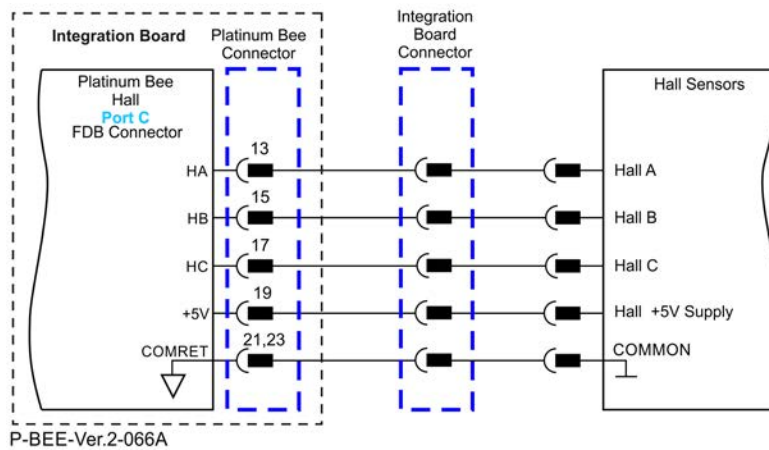

Figure 23: Hall Sensors Connection Diagram

8.9 Digital IO

Refer to the section 16.7 User I/Os in the Platinum Safety Drive Manual for details, specification and connection of the User IO connections.

8.9.1 Digital Inputs

The following table describes the electrical specification of the inputs IN1 and IN6:

Feature	Details
Input Voltage (VIN)	0 to 3.6V
V _{ih} min	2.2V
V _{il} max	0.6V
Minimum pulse width	> 250 μsec
Execution time (all inputs): the time from application of voltage on input until execution is complete	0 < T < 250 μsec
High-speed inputs – 1–6 minimum pulse width, in high-speed mode	T = 5 μsec if the input functionality is set to latch/capture (index/strobe). <div style="display: flex; align-items: center;"> <div> <p>Note: Home mode is high-speed mode and can be used for fast capture and precise homing.</p> </div> </div>
Capture with differential input Port A, Port B Index	T > 0.1 μsec if the differential input functionality is set to touch probe/capture (index/strobe).

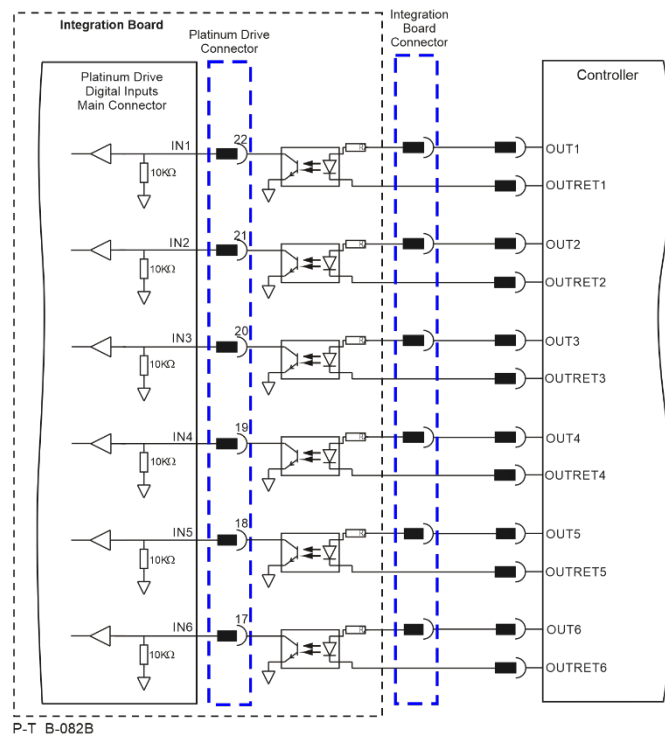
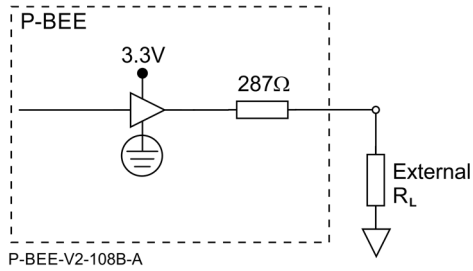
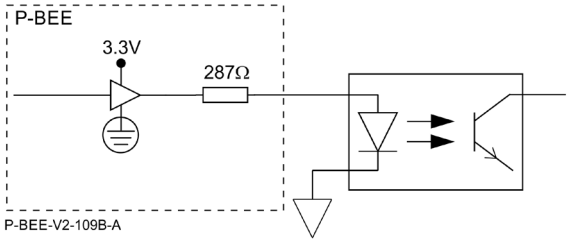

Figure 24: Digital Input 5V Logic level Mode Connection Diagram

8.9.2 Digital Outputs

Digital outputs 1 to 4 are 3.3V Logic.

The following table describes the electrical specification of outputs 1 to 4:

Feature	Details
Type of output	3.3V Logic
Output Configuration	
V_{OL} max of TTL Buffer (low level)	$V_{out} (Low) \leq 0.44V @ 8mA$
V_{OH} min of TTL Buffer (High level)	$V_{out} (High) > 4.4V @ 8mA$
Output current	$I_{out(max)} = \frac{3.3V}{287\Omega + R_L (external)}$ <p>Where:</p> $V_{R_L(High)} = 3.3V - 287 * I_{out(max)}$
Example of connection to the opto-couplers	 <p>Where:</p> $I_{out(max)} = \frac{3.3V - 2.0V}{287\Omega} = 4.5mA$
T_{on} (time from low to high)	<1μsec
T_{off} (time from high to low)	<1μsec
Executable time	$0 < T < 250 \mu sec$

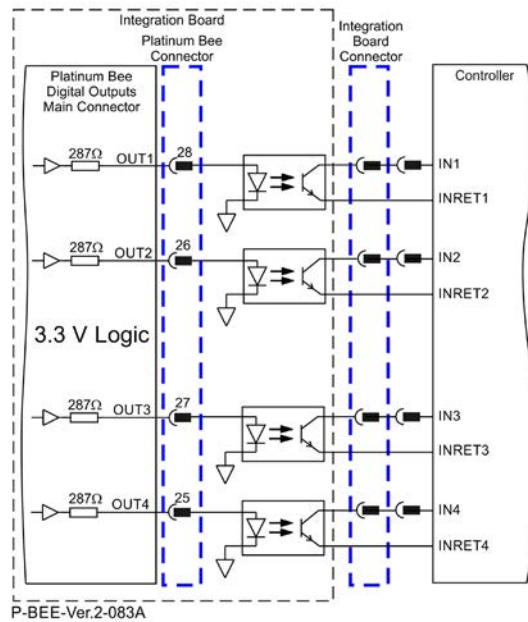

Figure 25: Digital Output 3.3V Logic Mode Connection Diagram

8.9.3 STO (Safe Torque Off)

Refer to the section 16.5 Safe Torque Off (STO) in the Platinum Safety Drive Manual for details, specification and connection of the STO.

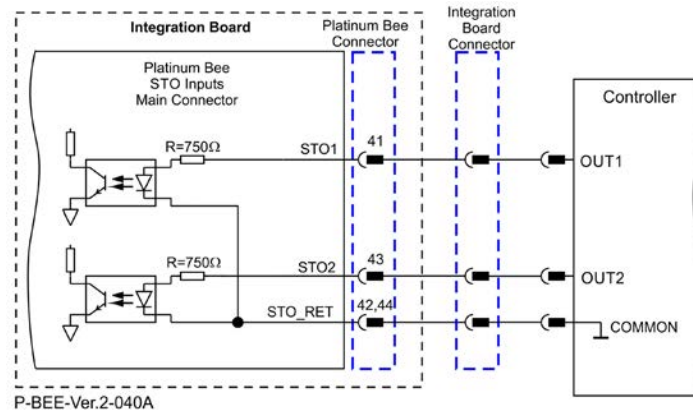

Figure 26: STO Input Connection – 5V Logic Level

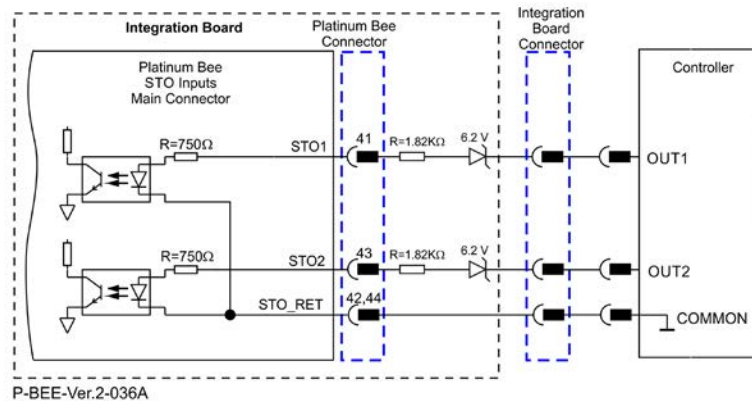

Figure 27: STO Input Connection – PLC (24V Logic)

8.10 Analog Inputs

There are two possible types of Analog Inputs in the Platinum Bee:

- Analog Input 1 – Differential ± 10 V
- Analog Input 2 – Single ended 3.3 V

Refer to the section 16.8 Analog Input in the Platinum Safety Drive Manual for details, specification and connection of the Analog Input.



Important:

It should be noted that throughout the Analog Inputs section the following applies:

For short distances between the drive and control, 0.5 to 1.0 m wires can be used and shielding is not required. For longer distances than 1.0 m and/or high EMI environment, shielded and twisted wires should be used. Drain wires should be connected to Elmo COMRET.

8.10.1 Analog Input 1

Figure 28 describes the input interface of the Analog input 1 in the Platinum Bee:

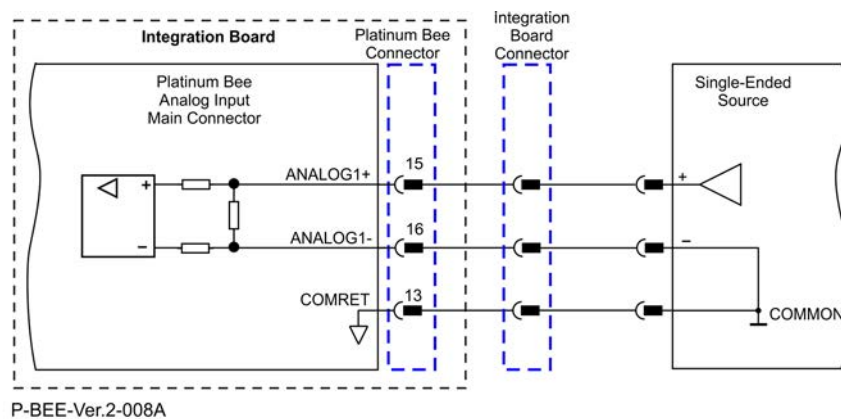

Figure 28: Analog Input 1

8.10.2 Analog Input 2

Figure 29 describes the input interface of the Analog input2 in the Platinum Bee.

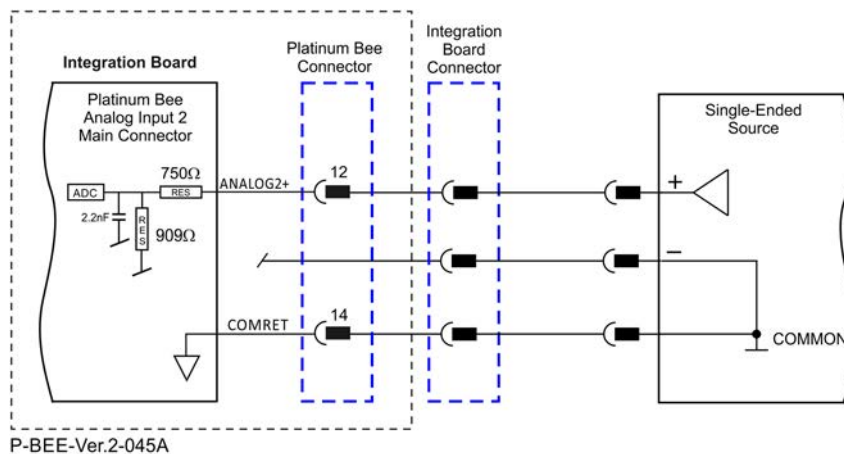

Figure 29: Analog Input 2

8.11 Communication

8.11.1 Serial Communication

here are two types of RS-232 Serial Communication: Standard RS-232 and RS-232 TTL Level.



Important:

It should be noted that throughout the RS-232/RS-422 sections the following applies:

For short distances between the drive and control, 0.5 to 1.0 m wires can be used and shielding is not required. For longer distances than 1.0 m and/or high EMI environment, shielded and twisted wires should be used. Drain wires should be connected to Elmo COMRET.

8.11.1.1 Standard RS-232 Serial Communication

Refer to section 16.10.3 RS-232 in the Platinum Safety Drive Manual for details, specification and connection of the RS-232 TTL Level.

Figure 30 describes the Standard RS232 connection diagram.

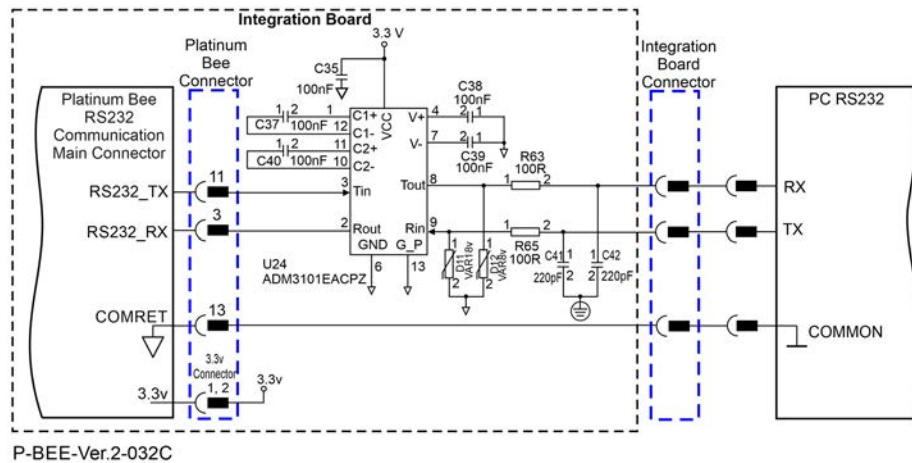

Figure 30: RS232 Serial Communication Connection Diagram

8.11.1.2 RS-422 (Differential RS-232) Serial Communication

The following is recommended when connecting the Differential RS-232 communication cable:

Connect the shield to the ground of the Controller.

Usually, this connection is soldered internally inside the connector at the PC end. You can use the drain wire to facilitate connection.

The following are RS-422 signals:

Signal	Function
RS-422_TX+	Differential RS-232 Transmit
RS-422_TX-	Differential RS-232 Transmit Complement
RS-422_RX+	Differential RS-232 Receive
RS-422_RX-	Differential RS-232 Receive Complement
COMRET	Common Return

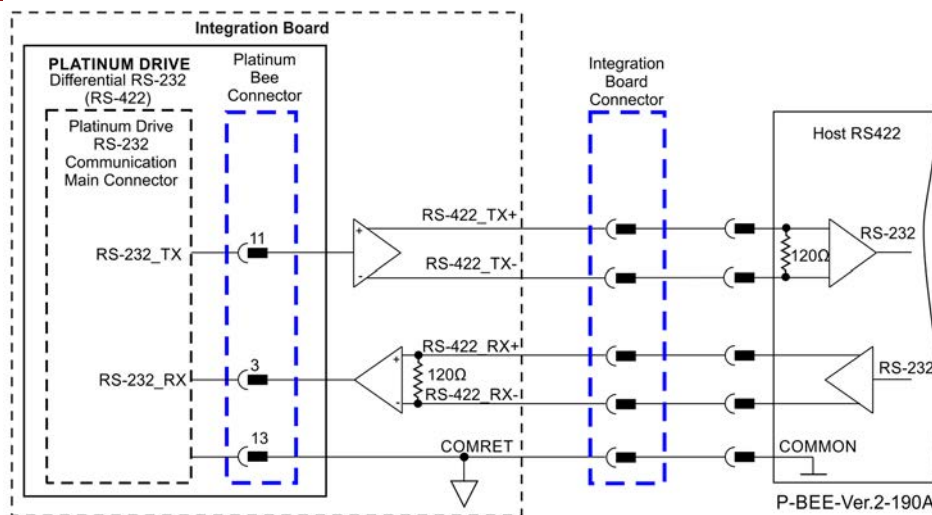

Figure 31: Differential RS-232 Serial Communication Connection Example

The RS-232 TTL Level will be used in order to connect Differential RS-232 (RS-422).

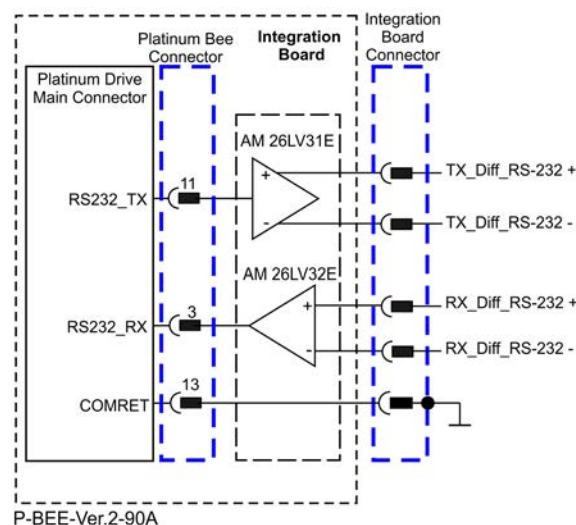

Figure 32: Differential RS-232 (RS-422) Serial Communication Connection Diagram

8.11.2 USB 2.0

Refer to section 16.10.1 USB in the Platinum Safety Drive Manual for details, specification and connection of the USB.



Important:

It should be noted that throughout the USB section the following applies:

For short distances between the drive and control, 0.5 to 1.0 m wires can be used and shielding is not required. For longer distances than 1.0 m and/or high EMI environment, shielded and twisted wires should be used. Drain wires should be connected to Elmo COMRET.

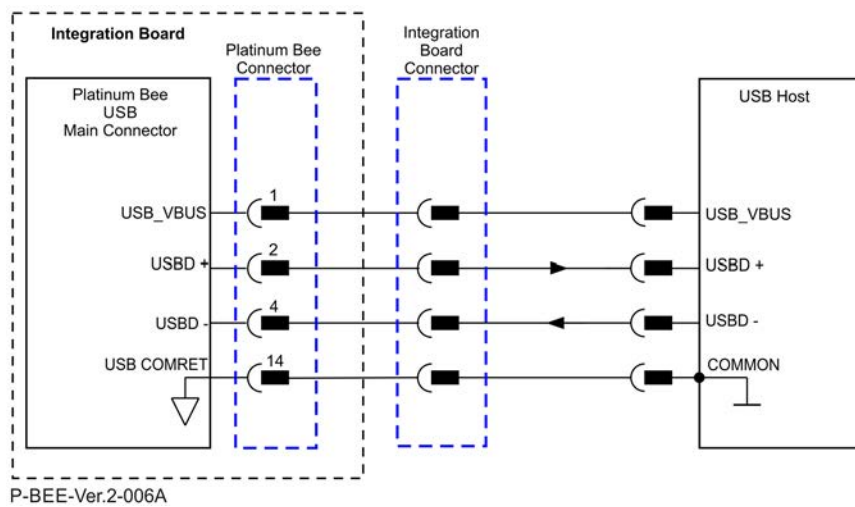

Figure 33: USB Network Diagram

8.11.3 EtherCAT/Ethernet Communication

This section only describes the EtherCAT communication, and the pinout drawing of the connector.

For details of the EtherCAT/Ethernet connections, refer to the [Platinum Safety Drive Manual.pdf Section 18.10.2 EtherCAT/Ethernet](#).

8.11.3.1 EtherCAT Status Indicator

Figure 34 describes the Pin associated with the EtherCAT status indicator.

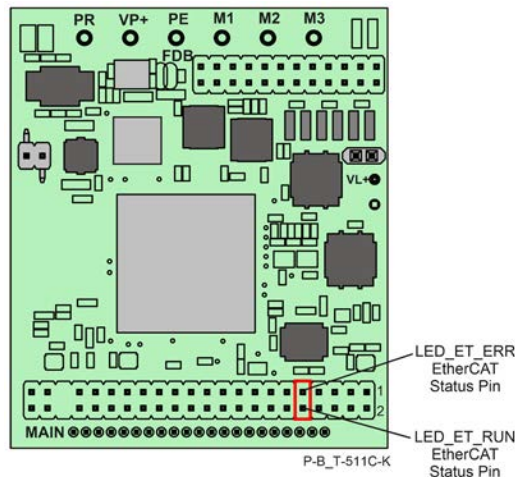

Figure 34: EtherCAT Status Indicator Pin

The EtherCAT status indicator is a single red/green dual bi-colored LED which is used for immediate indication of the Initiation and Working states.

8.11.3.2 EtherCAT Link Indicators

The Platinum Bee can serve as an EtherCAT slave device. For this purpose it has two Pins, which are designated as EtherCAT Link In and EtherCAT Link Out. Each of these Ports has a status LED; EtherCAT In and EtherCAT Out.

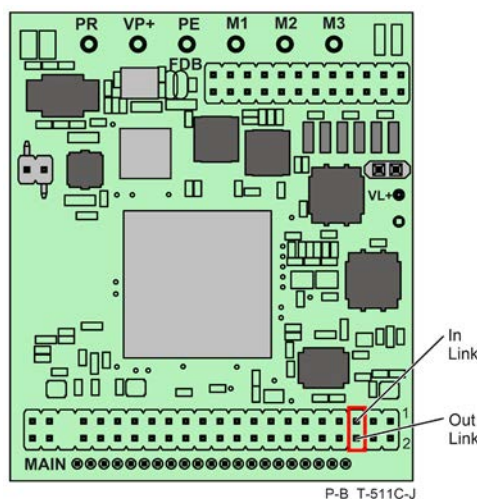

Figure 35: EtherCAT Link In and Out Pins

The green LEDs are the link/activity indicators. They show the state of the applicable physical link and the activity on that link; blinking green, for both Link Act IN, and Link Act OUT.

8.11.4 CAN

Figure 36 displays the CAN connectivity.

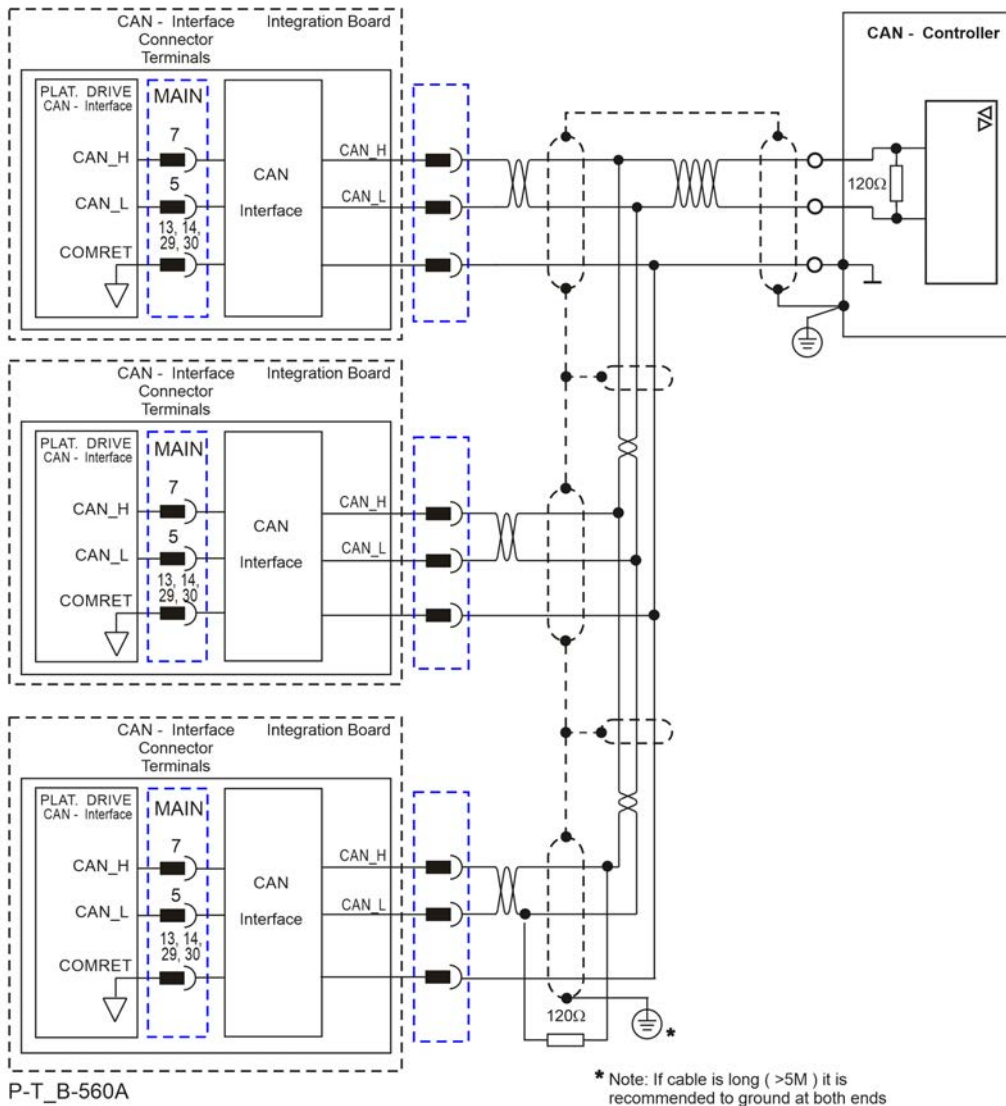

Figure 36: CANbus Connections



Important:

A 120 Ω termination resistor should be connected at each end of the network cable.

Chapter 9: Powering Up

After the Platinum Bee is connected to its device, it is ready to be powered up.



Caution:

Before applying power, ensure that the DC supply is within the specified range and that the proper plus-minus connections are in order.

9.1 Initializing the System

After the Platinum Bee has been connected and mounted, the system must be set up and initialized. This is accomplished using the *EASII*, Elmo's Windows-based software application. Install the application and then perform setup and initialization according to the directions in the *EASII User Manual*.

9.2 Heat Dissipation

The best way to dissipate heat from the Platinum Bee is to mount it so that its heat-sink is attached to the machine chassis. If mounted with its heat-sink suspended, then for best results mount the servo drive faced upwards and leave approximately 10 mm of space between the Platinum Bee's heat-sink and any other assembly.

9.2.1 Thermal Dissipation Data

The Heat Dissipation shown graphically below is applicable for an ambient of 25°C.

These graphs describe the basic Platinum Bee PN PBEE-Mz-zXXX/YYY-zz-Blank.

It should also be noted that the Heat Sink of the model PN PBEE-Mz-zXXX/YYY-zz-H can dissipate up to 5.5W.

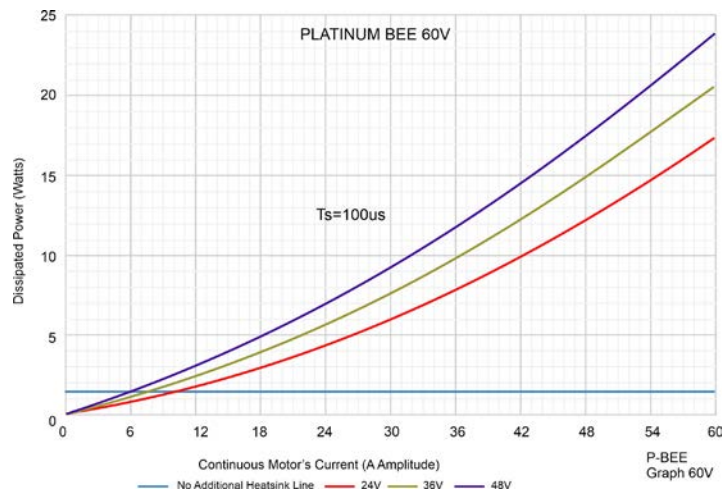

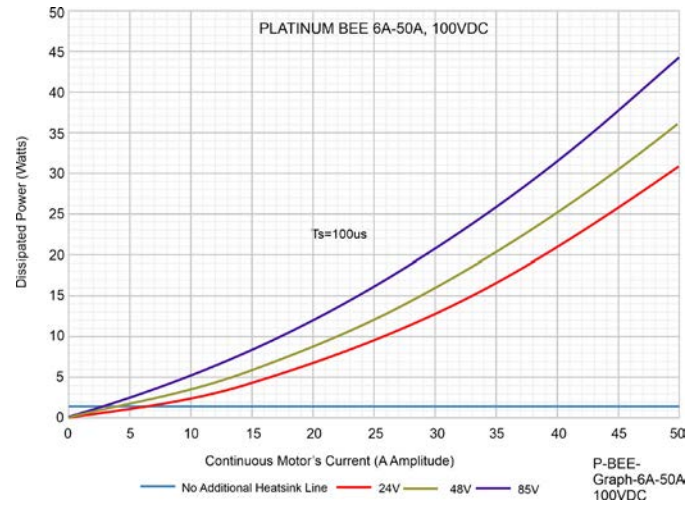
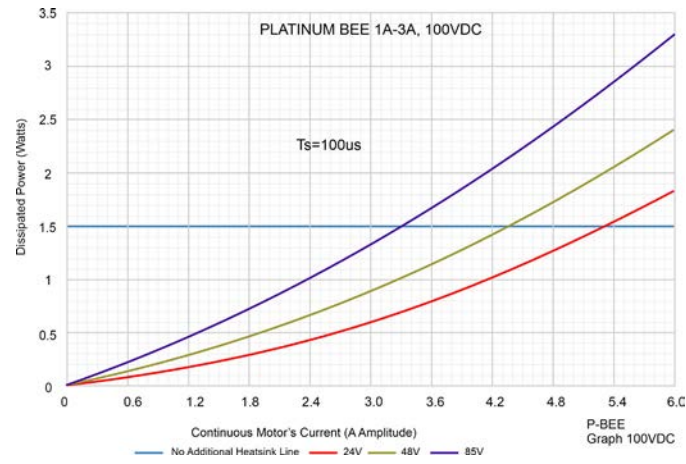
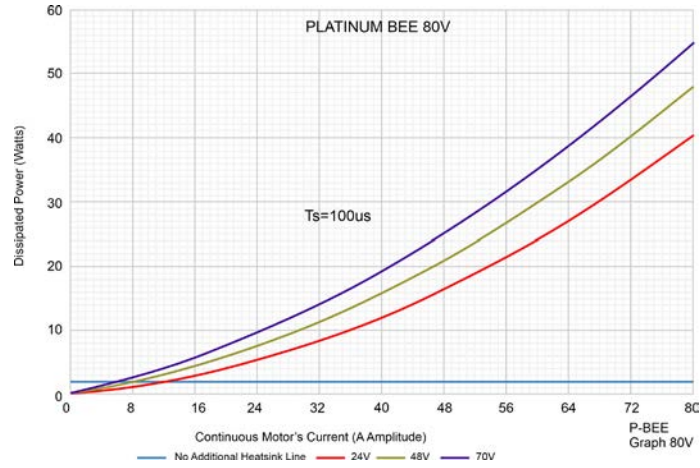

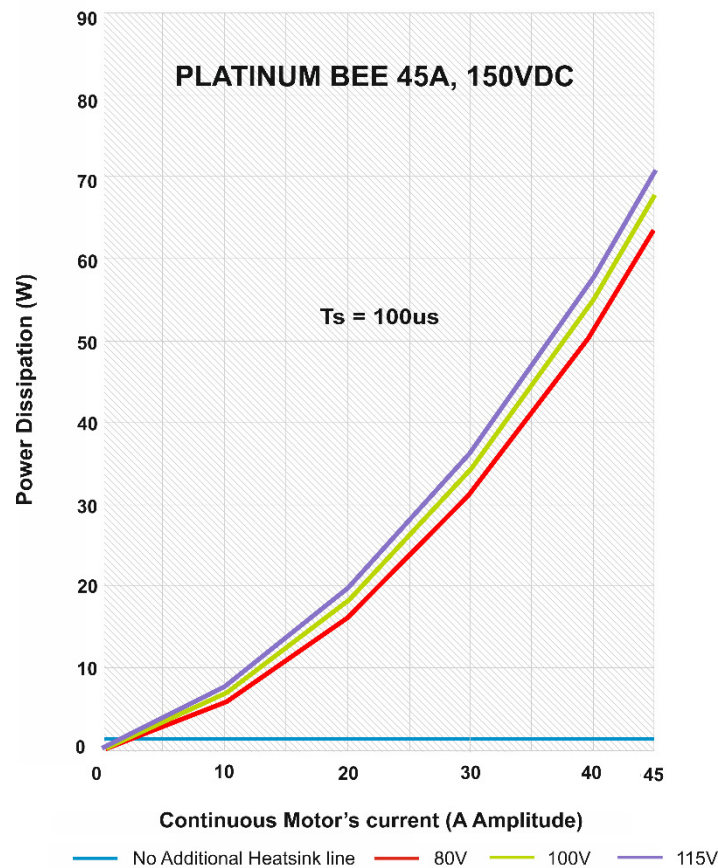
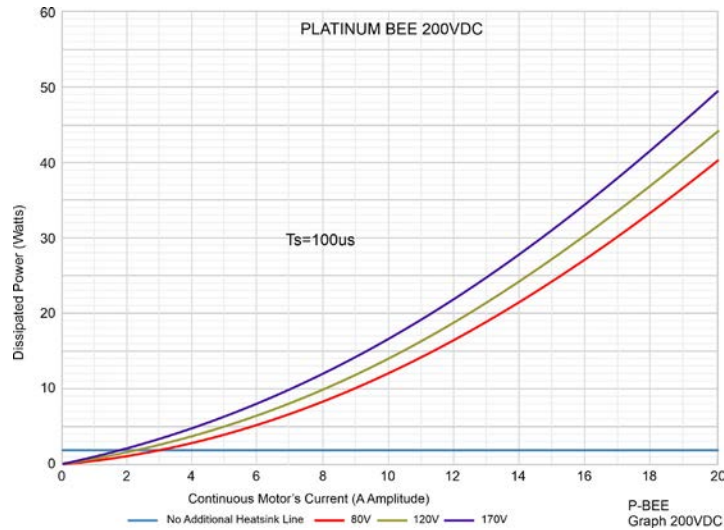

9.2.2 How to Use the Chart

The charts above are based upon the theoretical worst-case scenario. The actual test results display a 20% - 30% lower power dissipation.

The above charts indicate the net power conversion losses and exclude the control losses.

To determine if your application heat dissipation requires a heat sink:

1. Determine the power dissipation according to the "continuous current" and the DC bus voltage curve.
If the DC bus is not one of the three curves above, estimate the dissipation by interpolation. The estimation error is not critical.

2. The chart is calculated for continuous current operation, if the actual operation is pulsed current, add 25% to 30% to the power dissipation of the average (RMS) current.
3. When the Heat-Sink temperature reaches $\approx 85^{\circ}\text{C}$, the Platinum Bee will shut down.
Design the system for continuous operation so that the maximum Heat Sink temperature should be no higher than between 80°C to 82°C .
4. For model **PBEE-Mz-zXXX/YYYzz-Blank**
If the average heat dissipation is less than $\approx 1.5\text{W}$ (Average operating power of 100W to 200W) there will be no requirement for an external heat sink.
If the average Heat dissipation is higher than 1.5W then an additional heat dissipation means is required, usually by connecting to an external heat-sink.
For model **PBEE-Mz-zXXX/YYYzz-H**
If the average heat dissipation is less than $\approx 4\text{W}$ to 5W (Average operating power of 300W to 600W) there will be no requirement for an additional external heat sink.
If the average Heat dissipation is higher than 4W then an additional heat dissipation means is required, usually by connecting to an additional external heat-sink.
5. When an external Heat-Sink is required, calculate the thermal resistance of the heat sink according to:

$$\Phi_{^{\circ}\text{C}/\text{W}} = \frac{80^{\circ}\text{C} - T_{\text{Ambient}}}{\text{Heat Dissipation}}$$

Chapter 10: Dimensions

This chapter provides detailed technical dimensions regarding the Platinum Bee.

10.1 Platinum Bee without Heatsink

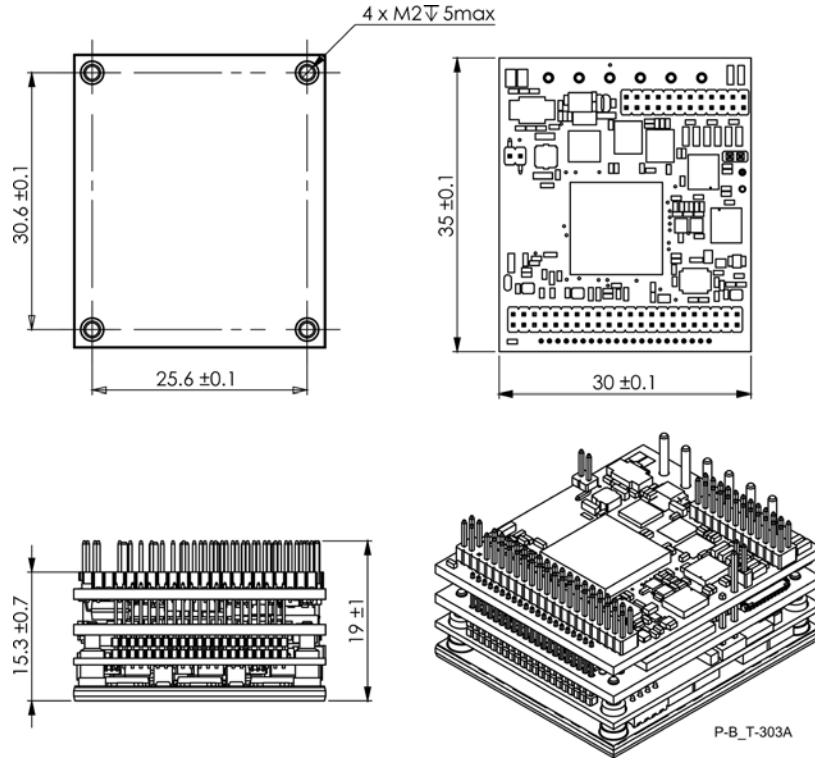

Figure 37: P-Bee –EtherCAT version

10.2 Platinum Bee with Heatsink

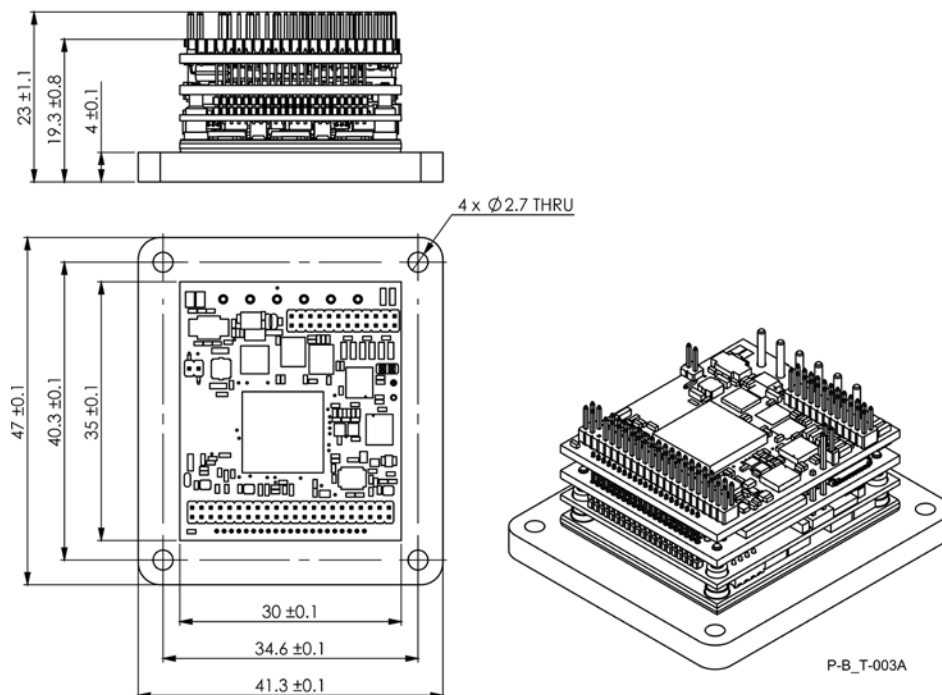

Figure 38: P-Bee –EtherCAT version with Flat Heatsink

*Go Safer, Smarter, Smaller, Simpler.
Go Platinum.*

Platinum 
by **Elmo**

www.elmocom.com